

SPH Coupled Simulation for Blast and Impact study on Reinforced Concrete Bunker buried under Soil

Priya Gautam¹, Hrishkesh Sharma²

¹Indian Institute of Technology Guwahati Assam India

²Indian Institute of Technology Guwahati Assam India

1 Abstract

This study examines how concrete structures respond to extreme conditions, particularly coupled simulation for blast and impact analysis, using LS-DYNA software for simulations. By analyzing displacement, pressure, strain, and stress, we aim to understand failure mechanisms and quantify damage in buried bunkers, providing insights for structural design and resilience assessments. In addition, coupled simulation for blast impact analysis, we consider durability and survivability under extreme conditions. This includes assessing long-term structural integrity, understanding environmental effects on material properties, and ensuring structures can function effectively after extreme events.

The study utilizes numerical simulations to assess the resistance of a buried bunker against coupled simulation analysis. The bunker, made of reinforced concrete with a thickness of 300 mm and a concrete grade of M40, is situated at a depth of 2 meters. Its reinforcement consists of steel with a yield stress (f_y) of 600 MPa.

In the simulations, the bunker and its surrounding soil are subjected to impacts from a rigid steel object with cylindrical dimensions—specifically, a diameter of 0.2 m and a height of 0.25 m below an explosive charge of 25 kg TNT in form of SPH having dimension 0.16 diameter and 0.04 m height. Both the explosive and the impactor are projected at velocities ranging from 100 m/s to 270 m/s. The objective of this study is to evaluate how these coupled simulation analysis scenarios influence the structural integrity and resilience of the bunker against explosive forces, providing insights into its performance under extreme conditions.

The primary motivation behind simulating coupled simulation for blast impact scenarios on a concrete bunker is to gain a comprehensive understanding of its load-bearing capacity during wartime events. Conducting actual experiments to assess the bunker's performance would incur significant costs, making it impractical and financially prohibitive. Therefore, the use of software like LS-DYNA simplifies the process and provides a more cost-effective approach to studying the behavior of the bunker under extreme conditions.

***KEYWORDS LS-DYNA, CONCRETE BUNKER, SPH, IMPACT ANALYSIS**

2 Introduction

A bunker is a military fortification designed to protect personnel and valuable assets from bomb attacks and other forms of assault. Historically, bunkers were extensively utilized during World War I, World War II, and the Cold War, serving not only as shelters but also as command centers, weapon storage facilities, and distribution points. In light of evolving threats from sophisticated conventional weapon detonations and terrorist attacks, there is an urgent need to enhance the resilience of these structures against modern challenges. To prevent structural failure, it is crucial to adopt appropriate geometrical configurations and consider the effects of coupled simulation for impact loads during the design process. Although such attacks are relatively rare, they represent dynamic loads that must be factored into

structural design, similar to earthquake and wind loads. Over the past decade, significant advancements have been made in developing structures that are more resistant to explosions.

By employing numerical simulations, researchers can efficiently analyze the bunker's response to various blast and impact coupled without the need for costly physical experiments. This approach allows for a thorough investigation of the bunker's structural integrity, resilience, and overall performance under extreme stress conditions, which is crucial for ensuring the safety and effectiveness of such structures during military operations.

The LS-Dyna simulations enable researchers to explore a wide range of scenarios, including variations in SPH TNT size, impact velocities, and soil conditions, without the limitations and risks associated with real-world testing. This flexibility allows for a more comprehensive understanding of the bunker's performance envelope and helps identify potential vulnerabilities or areas for improvement in its design and construction.

Furthermore, the use of LS-DYNA software-based simulations facilitates the rapid evaluation of different design iterations, enabling engineers to optimize the bunker's performance and cost-effectiveness. This approach ultimately contributes to the development of more robust and reliable protective structures that can withstand the challenges posed by modern warfare and ensure the safety of personnel and assets during times of conflict.

This paper outlines methods for mitigating the effects of detonations to safeguard human lives, structures, and critical equipment within. It reviews existing literature on blast loads and vulnerability assessments while focusing on the behavior of military bunker structures buried under soil in response to coupled simulation analysis. By examining these factors, the study seeks to contribute to the development of more effective protective measures for military bunkers in the face of extreme events.

3 Model

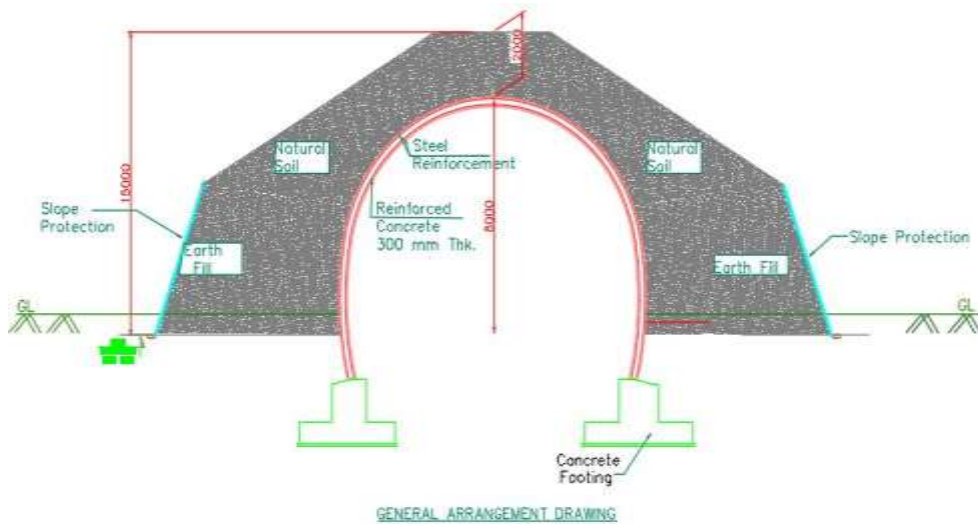

Fig. 1 GAD of Bunker

The primary objective of this study is to assess the capacity of soil to protect reinforced concrete structures from the devastating impact of a direct hit by a blast and impact coupled simulation, with terminal velocities ranging from 100 m/s to 270 m/s. To achieve this, a sophisticated finite element (FE) model was meticulously developed using LS-DYNA, employing the Smoothed Particle Hydrodynamics (SPH) technique to get an approximate idea to capture the complex dynamics of explosive interactions. A thorough validation of the material properties was conducted to ensure the model's precision, which

is essential for evaluating design and minimizing associated nuisances. The significance of this research lies in its potential to refine design strategies through the development of predictive equations. Key factors explored include charge weight, terminal velocity, bunker dimensions, burial depth, grades of reinforced concrete, and various soil types. By addressing these elements, the study aims to enhance the resilience of structures against explosive threats and contribute to safer design practices in blast-prone environments.

3.1 LS DYNA Model Overview

The LS-DYNA software was employed to model the structural response of buried reinforced concrete under explosive payloads. To optimize computational efficiency and reduce both the number of elements and nodes, a representative small section of the structure was simulated for various scenarios, as detailed below.

In the simulations, a bunker and its surrounding soil are subjected to impacts from a rigid steel object with cylindrical dimensions—specifically, a diameter of 0.2 meters and a height of 0.25 meters. Additionally, an explosive charge weighing 25 kilograms of SPH TNT having dimension as 0.16 m diameter and 0.04 m height, is included in the analysis. Both the explosive charge and the impactor are projected at velocities ranging from 100 m/s to 270 m/s, allowing for a comprehensive examination of their effects on the bunker structure and the surrounding environment.

To improve the overpressure prediction, a fine mesh size of 0.5 has been used. Symmetry conditions are used wherever possible to take care of mesh size without increasing the total number of elements.

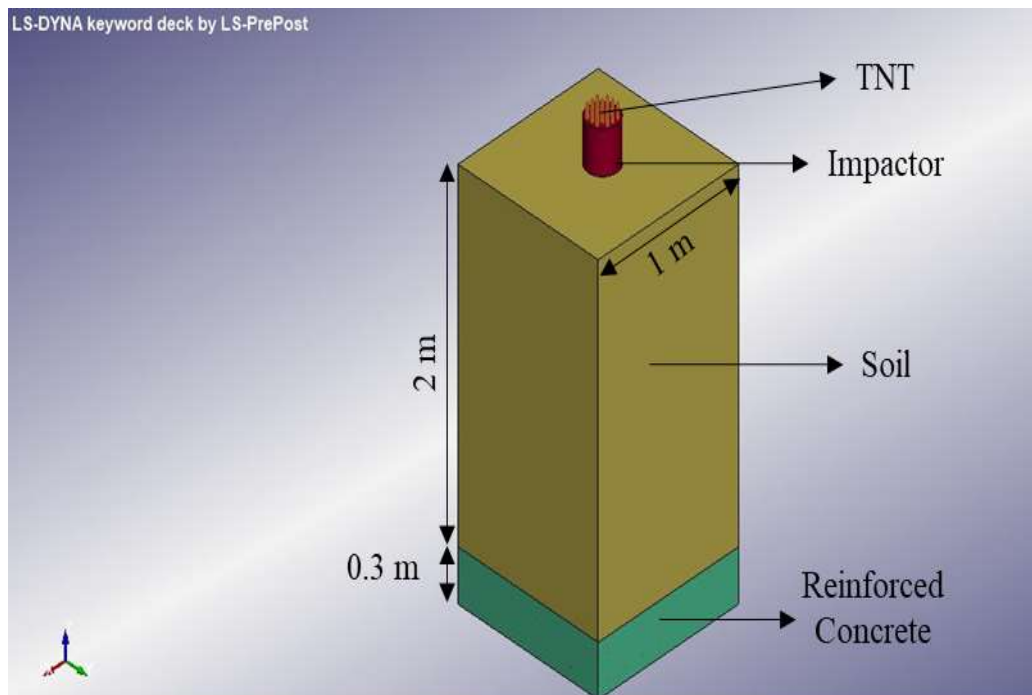

Fig. 2 FEM model of RC-soil bunker subjected to combined coupled simulation for blast and impact analysis

The pressure generated by the TNT chemical explosion is characterized by the MAT_HIGH_EXPLOSIVE_BURN model, employing the Jones-Wilkins-Lee (JWL) equation of state (EOS) with corresponding properties provided in the accompanying table. For the soil, the

Mat_soil_and_foam_failure material model was selected, while the steel reinforcement was represented using the PLASTIC_KINEMATIC_MAT_003 material model. The MAT159, MAT_CSCM_CONCRETE model for the concrete requires the input of three crucial parameters: unconfined compressive strength, aggregate size, and units, which can significantly influence the stiffness, yield strength, hardening, and damage-based softening of the material within the specified range. The contact between the TNT and other materials. i.e., concrete, reinforcement, and impactor was taken as CONTACT_AUTOMATIC_NODES_TO_SURFACE. At the junction of soil and concrete, AUTOMATIC_SURFACE_TO_SURFACE contact was considered and the effect of impactor on the (soil, concrete) and reinforcement was taken care of with ERODING_SURFACE_TO_SURFACE and ERODING_NODES_TO_SURFACE, respectively. All the material cards and contacts were validated from on the experiments conducted by (Chi et al., 2023), (J. Wang, 2001), (Shuaib & Daoud, 2016).

3.2 Material Validation and Properties

The material validation of soil is taken from a paper by J. Wang (2001), which utilized LS-DYNA 3D software for simulating landmine explosions, serving as a benchmark for explosive simulations in soil. Furthermore, the response of soil subjected to blast loading can be thoroughly analyzed using appropriate soil material models, enhancing our understanding of soil behavior under such extreme conditions.

The validation of reinforced concrete material is based on the study "Numerical Analysis of RC Slab Under Blast Loads Using the Coupling of LBE and ALE Methods in LS-DYNA" by Shuaib and Daoud (2016). The effective strain results were closely mirrored those presented in the reference paper, indicating consistency in findings. Hence, we are utilizing the properties of reinforcement bars to construct a frame structure that will support our steel bunker, while also applying the concrete material properties outlined in their research.

The material properties corresponding to MAT_008, MAT_003, MAT_159, and MAT_014 are shown in Tables 1, 3, 4, and 5, respectively. The parameters for Jones-Wilkins-Lee (JWL) EOS for TNT are shown in Table 2.

Table 1 Mat_008_HIGH_EXPLOSIVE_BURN material properties (Chi et al., 2023)

Density, (ρ) kg/m ³	Detonation velocity, (D) m/s	Chapman-Jouget pressure, (PCJ) GPa
1630	6930	21

Table 2 JWL EOS material properties (Chi et al., 2023)

A, GPa	B, GPa	R1	R2	Omega	Internal energy den- sity, (Eo) J /m ³	Initial relative volume, (V0)
371.2	3.231	4.15	0.95	0.30	7.0e+09	1.0

Table 3 PLASTIC_KINEMATIC material properties (Shuaib & Daoud, 2016;)

Density, (ρ) kg/m ³	Elastic modulus, (E) GPa	Poisson's ratio(ν)	Yield strength, (σ_y) MPa
7830	200	0.30	600

Table 4 MAT_159_CSCM_CONCRETE material properties (Shuaib & Daoud, 2016)

Density, (ρ) kg/m ³	Compressive strength (MPa)	ERODE	DAGG
2400	39.5	1.1	0.019

Table 5 MAT_014_SOIL_AND_FOAM_FAILURE material parameters (J. Wang, 2001)

Density, (ρ) kg/m ³	1800
Shear modulus, (G) GPa	0.0639
Bulk modulus, (K) GPa	30
A0, A1, A2, PC	3.4e+09, 7.033e+04, 0.30e+0, -6.90e+03
VCR, REF	0.0, 0.0
Volume strain ($\log(v/v_0)$) ϵ_1 , ϵ_2 , ϵ_3 , ϵ_4 , ϵ_5	0, -0.104, -0.161, -0.192, -0.224
ϵ_6 , ϵ_7 , ϵ_8 , ϵ_9 , ϵ_{10}	-0.246, -0.271, -0.283, -0.29, -0.40
Pressure (N/m ²) P1, P2, P3, P4, P5	0.0, 2x10 ⁷ , 4x10 ⁷ , 6x10 ⁷ , 1.2x10 ⁸
P6, P7, P8, P9, P10	2x10 ⁸ , 4x10 ⁸ , 6x10 ⁸ , 8x10 ⁸ , 4.1x10 ⁹

Boundary conditions play a crucial role in shock wave analysis, as they can reflect waves upon reaching the model's edges. Traditionally, model boundaries were set far apart to allow waves to dissipate before encountering the boundary, resulting in larger model dimensions and longer analysis times. In contrast, LS-DYNA offers the *NON_REFLECTING_BOUNDARY keyword, which defines half-space boundaries. This approach assumes that the same material continues beyond the boundary, preventing wave reflections and thereby reducing model size and computation time. In this study, it is assumed that soil extends both horizontally and vertically, so this command was applied to both the sides and bottom of the model. For the simulation setup, a non-reflecting boundary condition was implemented for the soil to minimize wave reflections and enhance analysis accuracy, while a fixed boundary condition was used for the concrete to accurately represent its immobility within the model.

The analysis of impact scenarios involving a rocket launcher with a maximum velocity of 245 m/s necessitates varying the impact velocity between 100 m/s and 270 m/s. The extensive range of simulated velocities has provided valuable insights into the gradual changes in the bunker's behavior and its capacity to withstand extreme loading conditions previously mentioned. This comprehensive analysis allows us to identify the thresholds at which the bunker can safely endure various impact and explosive scenarios, enhancing our understanding of its structural resilience under such challenging circumstances.

4 Results and Discussions

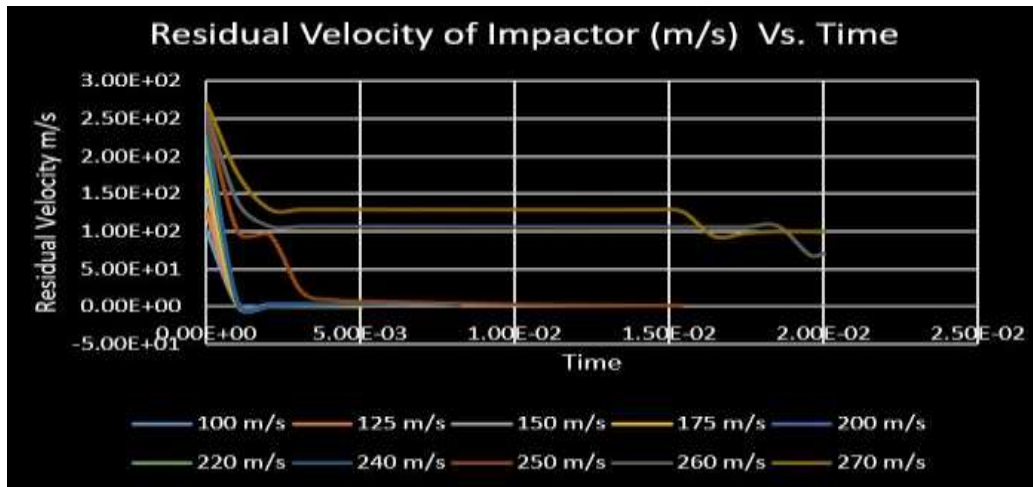

Fig. 3 Velocity vs time plots of impactor for different initial velocities

Figure 3, the residual velocity plots of the impactor interacting with soil and concrete layers consistently show a steady decrease in residual velocity upon contact with the soil. This reduction can be attributed to energy dissipation mechanisms, where the kinetic energy of the impactor is absorbed by the soil through deformation and compaction. Factors such as soil type, moisture content, and the friction coefficient at the soil-concrete interface play significant roles in this interaction. For example, sandy soils typically exhibit different shear displacement characteristics compared to clayey soils, affecting how quickly they absorb energy. Additionally, variations in moisture content can alter the shear strength parameters, further influencing the rate of velocity reduction. Overall, understanding these dynamics is crucial for predicting structural responses in engineering applications involving soil and concrete interfaces.

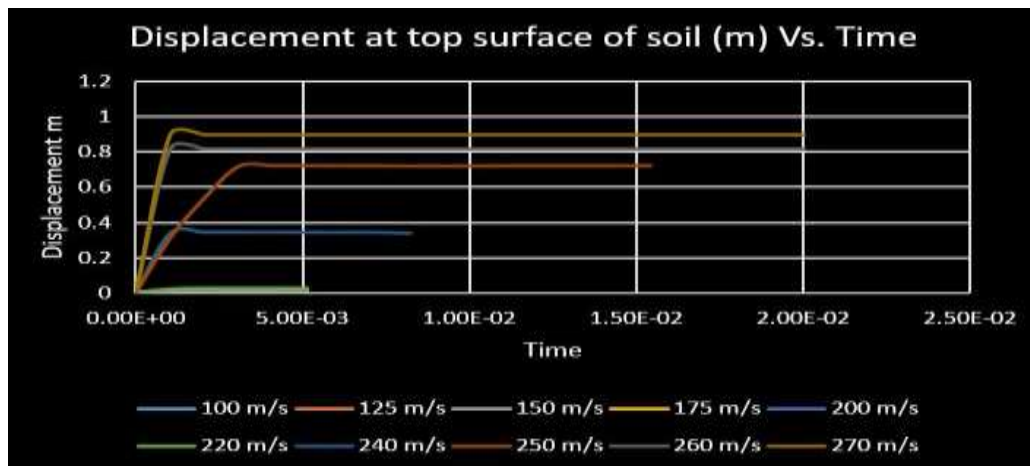

Fig. 4 Displacement of soil top-layer upon interaction with impactor with different velocities

Fig. 4 depicts The displacement of soil in relation to varying impactor velocities, while maintaining a constant payload, reveals a consistent trend across all scenarios: an initial increase in displacement followed by a plateau. The plots indicate that as the impactor velocity increases, the rate of soil displacement also rises, demonstrating a direct correlation between impactor speed and soil movement. Notably, for velocities of 260 m/s and 270 m/s, the displacement reaches a constant value, suggesting that these higher velocities lead to a threshold beyond which additional increases in speed do not

significantly affect soil displacement. This behavior highlights the dynamic response of soil to impact forces and indicates that there may be limits to how much displacement can be achieved regardless of further increases in impactor velocity.

Utilizing soil as a barrier between the bunker and the rigid impact of explosives significantly mitigates ground shock propagation as it travels toward the bunker. This protective layer effectively absorbs and dissipates energy, ensuring that the shockwave does not reach the bunker at velocities exceeding 250 m/s. As a result, the bunker experiences minimal to no significant damage on its surface, enhancing its overall structural integrity during extreme loading events.

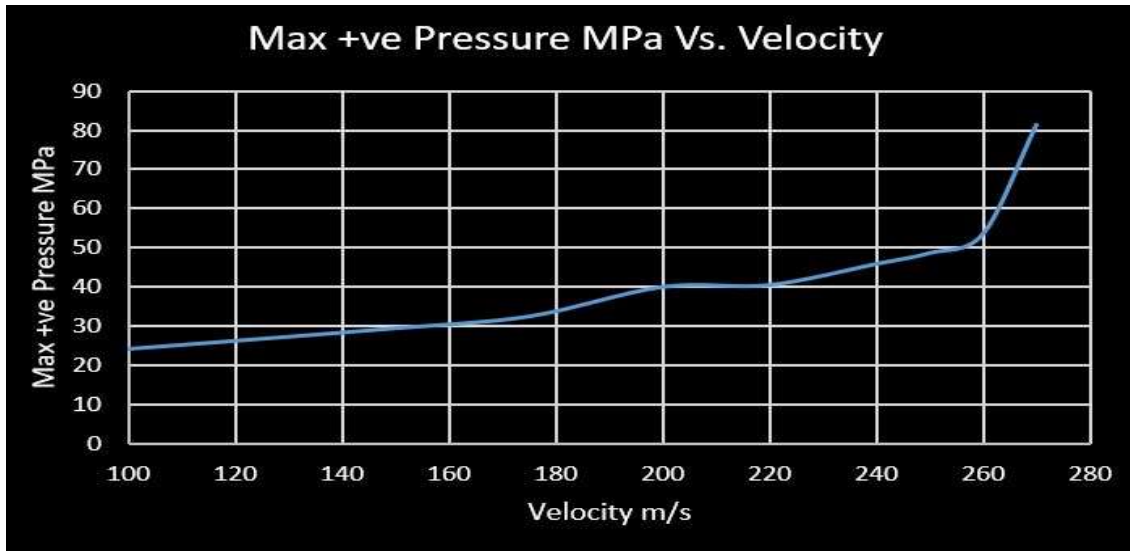

Fig. 5 Max Pressure MPa Vs. Velocity Plot

In figure 5 the plot trend can be explained by the dynamics of shock wave propagation and soil-structure interaction. As the impactor velocity rises, the energy transferred to the bunker increases, resulting in higher pressure exerted on the concrete surface. The initial phase of the impact generates a shock wave that travels through both the soil and the concrete, leading to an increase in pressure as the wave compresses the materials. Additionally, the presence of soil around the bunker plays a crucial role; it can amplify the pressure due to its ability to transmit dynamic loads effectively while also providing resistance against penetration. As velocities approach critical thresholds, such as those seen during extreme loading conditions, the rate of pressure increase may stabilize as the structural limits of the bunker are reached, demonstrating its capacity to withstand high-velocity impacts while effectively dissipating energy through deformation and material interactions.

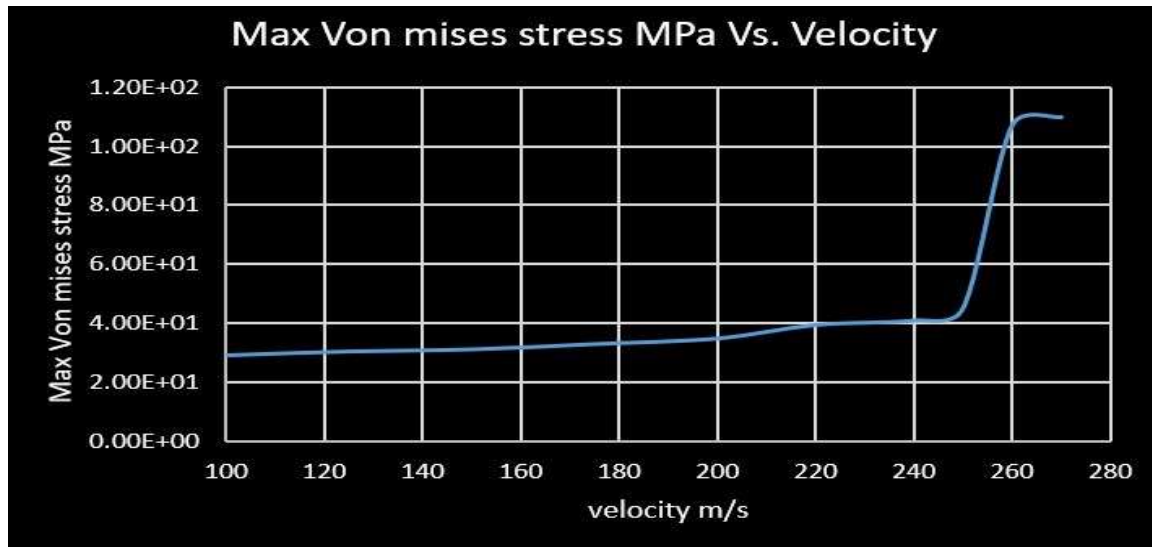

Fig. 6 Max Von Mises Stress MPa Vs. Velocity Plot

In fig 6 The von Mises stress versus velocity plot for a concrete bunker subjected to coupled simulation for blast and impact loading exhibits a gradual increase in stress up to 240 m/s, followed by a sharp rise beyond this velocity. This behavior can be attributed to the increasing dynamic loads experienced by the bunker as impactor velocities rise. Initially, at lower velocities, the soil plus concrete assembly can effectively absorb and dissipate energy, resulting in relatively low von Mises stress levels. However, once the velocity exceeds 240 m/s, the energy imparted by the impactor surpasses the material's capacity to withstand stress without yielding, leading to a rapid increase in stress levels. At 250 m/s, the impactor penetrates the soil, transferring significant energy directly to the concrete, causing visible damage. By 270 m/s, the stresses exceed the concrete's ultimate strength, resulting in structural failure of the bunker. This plot illustrates the critical thresholds of material performance under extreme loading conditions and highlights the importance of understanding dynamic responses when designing protective structures against this coupled simulation.

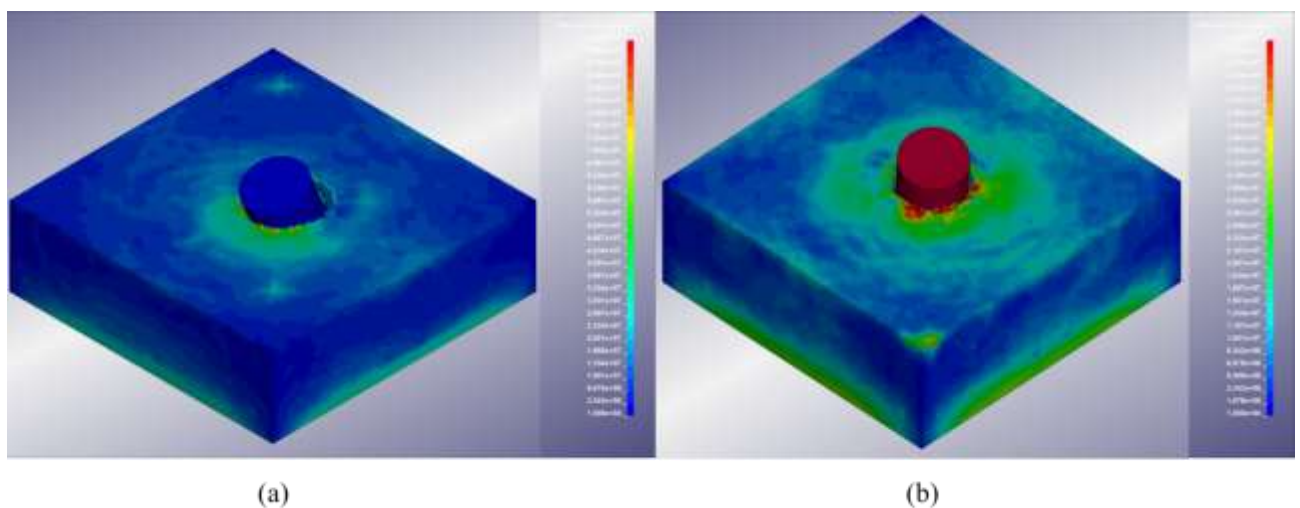

Fig. 7 Penetration of RC slab in case of (a) 260 m/s and (b) 270 m/s velocity, respectively

Fig 7 shows that at an impact velocity of 260 m/s, the impactor successfully penetrates the soil barrier and targets the surface of the bunker. However, the robust construction and design of the bunker effectively thwart the impactor's progression, resulting in a significant reduction of its velocity to a residual speed of 60 m/s before it ultimately comes to a complete stop. This outcome underscores the exceptional resistance of the bunker to high-velocity impacts, demonstrating the effectiveness of its structural reinforcement and the strategic placement of the soil barrier in mitigating the effects of extreme loading conditions. Such findings emphasize the importance of integrating strong design features in protective structures to enhance their resilience against dynamic forces.

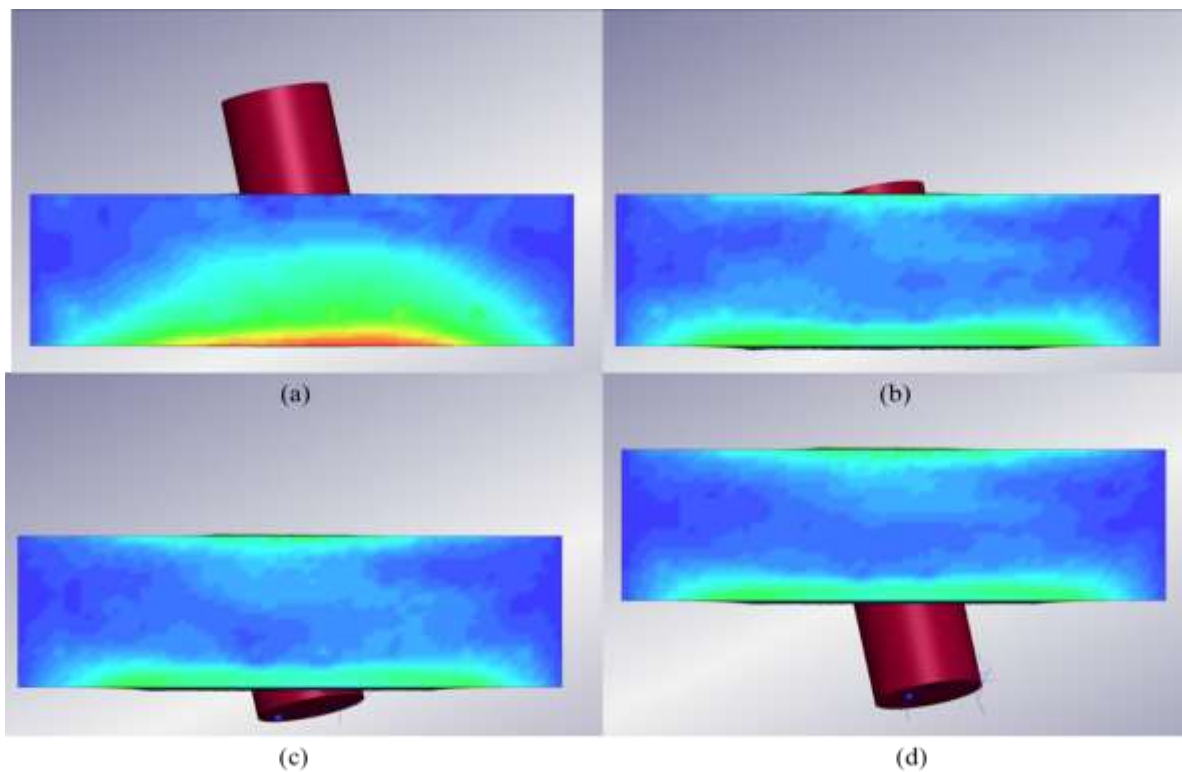

Fig. 8 Sequential penetration of RC slab with impactor at 270 m/s

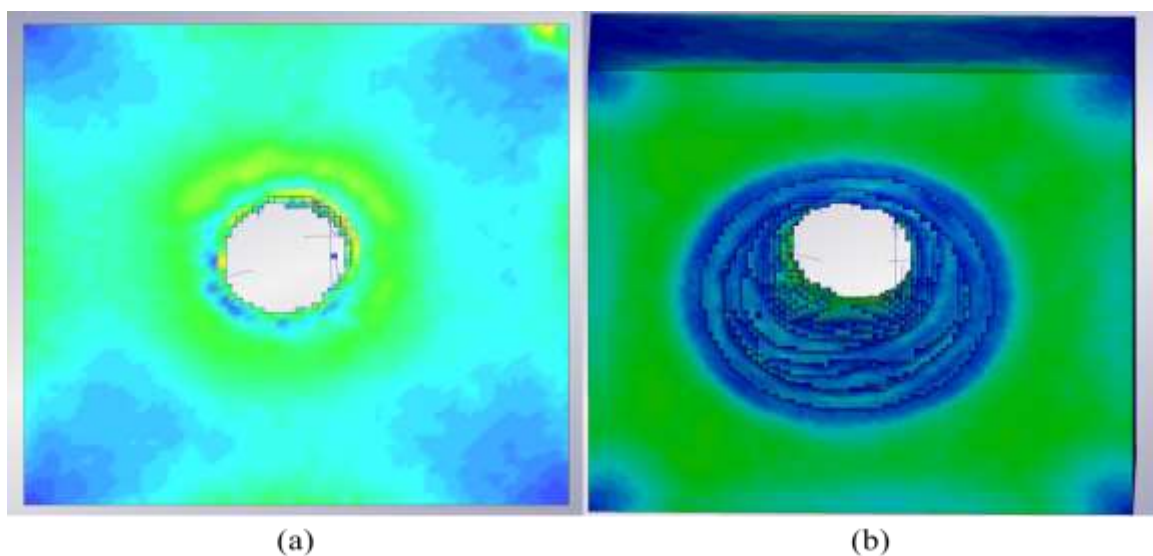

Fig. 9 (a) Top and (b) bottom view of failure profile of RC slab under impactor of 270 m/s velocity

At an impact velocity of 270 m/s, the impactor successfully penetrates both the soil barrier and the concrete structure of the bunker. Notably, the penetration hole on the top surface is smaller compared to the bottom surface. This discrepancy arises because the concrete offers substantial resistance against the impact, causing the impactor to tilt during penetration. As a result, the exit hole is larger than the entry hole. Ultimately, the impactor exits with a residual velocity of 100 m/s, illustrating the dynamic interaction between the impactor and the bunker's structural components during high-velocity impacts.

5 Summary

The present study has successfully demonstrated the efficacy of Smoothed Particle Hydrodynamics (SPH) coupled simulation for impact analysis on reinforced concrete structures using LS-DYNA software. Our model, which incorporates a soil barrier between the concrete bunker and the impacting object, has provided valuable insights into the behavior of protective structures under high-velocity impacts. The simulations effectively captured the response of the reinforced concrete bunker to impacts with velocities ranging from 100 m/s to 270 m/s, revealing critical thresholds for structural integrity and penetration resistance.

The results of our impact simulations show that the concrete bunker can withstand rigid impacts up to a velocity of 250 m/s without significant damage to its surface. At higher velocities, we observed interesting phenomena such as the complete penetration of the soil barrier at 260 m/s and the full penetration of both soil and concrete at 270 m/s. These findings are particularly relevant for predicting the effects of kinetic energy rounds on reinforced concrete structures, offering valuable data for the design and assessment of protective installations.

Our model's ability to accurately represent the interaction between the impactor, soil, and concrete structure demonstrates its potential for application in various fields, including civil engineering, defense technology, and infrastructure protection. The detailed analysis of residual velocities, soil displacement, and penetration profiles provides a comprehensive understanding of the dynamic behavior of reinforced concrete under extreme loading conditions.

However, it is important to note that while our study has made significant strides in simulating impact scenarios, the simulation of blast effects requires further research and development. The complex nature of explosive detonations, including the rapid release of energy, pressure wave propagation, and the interaction of these phenomena with surrounding materials, presents additional challenges that were not fully addressed in the current model.

The simulation of blast effects involves modeling highly nonlinear material behaviors, fluid-structure interactions, and rapid deformations that occur on extremely short time scales. These factors necessitate more advanced numerical techniques and material models that can accurately capture the physics of explosions and their effects on structures. Future research should focus on integrating sophisticated blast modeling techniques with the current impact simulation framework to create a more comprehensive tool for analyzing reinforced concrete structures under combined blast and impact loading.

To achieve this, several avenues of research could be pursued. These include the development of more refined material models for concrete and soil that can account for strain-rate effects and dynamic failure mechanisms under explosive loading. Additionally, the incorporation of advanced fluid dynamics models to simulate the propagation of blast waves through air and soil would enhance the accuracy of the overall simulation. Coupling these improvements with the existing SPH methodology could lead to a more robust and versatile simulation tool.

In conclusion, while our current model provides valuable insights into the impact resistance of reinforced concrete structures, it also highlights the need for continued research in the field of blast simulation. The successful implementation of impact modeling serves as a strong foundation for future work, demonstrating the potential of numerical simulations in predicting structural responses to extreme loading events. As research in this area progresses, it is anticipated that combined impact and blast simulations will become increasingly accurate and useful for the design and analysis of protective structures, ultimately contributing to enhanced safety and resilience in critical infrastructure.

6 References

- Baker, W. E. (1974). Explosions in Air Part One. In Development.
- Beshara, F. B. A. (1994). Modelling of blast loading on aboveground structures-I. General phenomenology and external blast. *Computers and Structures*, 51(5). [https://doi.org/10.1016/0045-7949\(94\)90066-3](https://doi.org/10.1016/0045-7949(94)90066-3)
- Brode, H. L. (1955). Numerical solutions of spherical blast waves. *Journal of Applied Physics*, 26(6). <https://doi.org/10.1063/1.1722085>
- Chi, K., Li, J., & Wu, C. (2023). Numerical simulation of buried steel pipelines subjected to ground surface blast loading. *Thin-Walled Structures*, 186. <https://doi.org/10.1016/j.tws.2023.110716>
- Dharaneepathy, M. V., Rao, M. N. K., & Santhakumar, A. R. (1995). Critical distance for blast-resistant design. *Computers and Structures*, 54(4). [https://doi.org/10.1016/0045-7949\(94\)00380-L](https://doi.org/10.1016/0045-7949(94)00380-L)
- Gilbert F. Kinney, & Kenneth J. Graham. (1985). *Explosive Shock in Air*. Springer Science+Business Media, LLC.
- Goel, M. D., Matsagar, V. A., Gupta, A. K., & Marburg, S. (2012). An abridged review of blast wave parameters. In *Defence Science Journal* (Vol. 62, Issue 5). <https://doi.org/10.14429/dsj.62.1149>
- Henrych, J., & Abrahamson, G. R. (1980). The Dynamics of Explosion and Its Use. *Journal of Applied Mechanics*, 47(1). <https://doi.org/10.1115/1.3153619>
- Izadifard, R. A., & Foroutan, M. (2010). Blastwave parameters assessment at different altitude using numerical simulation. *Turkish Journal of Engineering and Environmental Sciences*, 34(1). <https://doi.org/10.3906/muh-0911-39>
- Ngo, T., Mendis, P., Gupta, A., & Ramsay, J. (2007). Blast loading and blast effects on structures - An overview. *Electronic Journal of Structural Engineering*, 7. <https://doi.org/10.56748/ejse.671>
- Shuaib, M., & Daoud, O. (2016). Numerical analysis of rc slab under blast loads using the coupling of lbe and ale methods in ls-dyna. *Fib Symposium*.
- UFC 3-340-02. (2008). *Unified Facilities Criteria (Ufc) Structures To Resist the Effects of Accidental Explosions*. Unified Facilities Criteria U.S. ARMY CORPS OF ENGINEERS, December.
- Wang, J. (2001). *Simulation of a landmine explosion using LS-DYNA3D software*. Australia: Department of Defence, DSTO-TR116.
- Wang, W., Zhang, D., Lu, F., Wang, S. chuan, & Tang, F. (2013). Experimental study and numerical simulation of the damage mode of a square reinforced concrete slab under close-in explosion. *Engineering Failure Analysis*, 27. <https://doi.org/10.1016/j.engfailanal.2012.07.010>
- Zhang, C., Gholipour, G., & Mousavi, A. A. (2020). Blast loads induced responses of RC structural members: State-of-the-art review. In *Composites Part B: Engineering* (Vol. 195). <https://doi.org/10.1016/j.compositesb.2020.108066>
- Blast Resistant Design A Primer for Architects © 2022, Muhammad A. Siddiqui, AIA