

Material Models for Thermoplastics in LS-DYNA® from Deformation to Failure

P. Reithofer, A. Fertschej, B. Hirschmann, B. Jilka, M. Rollant
4a engineering GmbH

Abstract

In the last years the demands of the automotive industry have led to a strong interest for a more detailed description of the behavior of thermoplastic materials and thus for more complex material cards including damage and failure. Also, the importance of gaining material data quickly has risen.

Currently material and failure modeling in crash simulations typically deal with simple von Mises visco-plasticity (*MAT_024) and equivalent strain failure criteria, which cannot describe the complex material behavior of plastics. Past developments have focused on the yield behavior under different load situations (tension, shear, compression), which are implemented in more complex material models like *MAT_SAMP-1.

In the last decade 4a engineering began generating material cards out of dynamic bending tests as an efficient alternative to these “old school” tests. For this reason the testing device IMPETUS™ was developed. The bending tests are used to get the visco-plastic material behavior as well as the visco-elasticity (*MAT_024). The bending load case represents an average between tension and compression behavior and is therefore closer to real part behavior. Using further tests like the dynamic bending tensile test the tension-compression asymmetry can be characterized and considered in more complex material models like *MAT_SAMP-1. For damage and failure modeling further tests are required (e.g. puncture test). All these tests can be conducted using the test device IMPETUS™.

The software VALIMAT™ is used for the material modeling process. VALIMAT™ can be used as stand-alone software or in combination with IMPETUS™. Of course, external test data from universal or other testing devices can also be imported and used for the subsequent material modeling. The material modeling is done using a reverse engineering procedure with the help of LS-OPT®. For this an almost automatic workflow in VALIMAT™ was developed to identify the necessary material parameters in the material cards, for both *MAT_024 and *MAT_SAMP-1.

In the present contribution the principal behavior of three commonly-used material models for plastics and their individual advantages and disadvantages are discussed.

The material characterization using “old school” tests is opposed to the smart approach using IMPETUS™ and bending tests. The material Hostacom XBR169, a talc filled PP, is characterized and material cards based on the three material models are generated and compared. Finally, failure is considered and the resulting material card *MAT_SAMP-1 with *MAT_ADD_EROSION (GISSMO) is validated on a small part.

The results prove the capability of IMPETUS™ and VALIMAT™ for fast and accurate material card generation.

Introduction

In recent years the demand on safety relevant plastic parts in the automotive industry has led to a strong interest for a more detailed description of the behavior of thermoplastic materials and thus more complex material cards. Was it first the interest on the deformation behavior of plastics under different loading conditions (tension, shear, compression → *MAT_SAMP-1), nowadays the failure of this material group is of researching interest.

Although some material models in LS-DYNA especially for thermoplastics were developed, the material and failure modeling in crash simulations typically deal with simple J2 plasticity (*MAT_024) and mean strain failure criteria, which cannot describe the complex material behavior of plastics.

Reasons can be found in the higher computational effort [1] [2] as well as in higher time and cost consumption of the material characterization. In this paper we would like

- to summarize our experience of the last 15 years in the mentioned field
- to give a rough overview of and compare the commonly used material models for plastics
- to show different ways how to perform material characterizations
- to show how our products IMPETUS™ as well as VALIMAT™ can be efficient solutions to gain LS-DYNA material cards for crashworthiness applications.

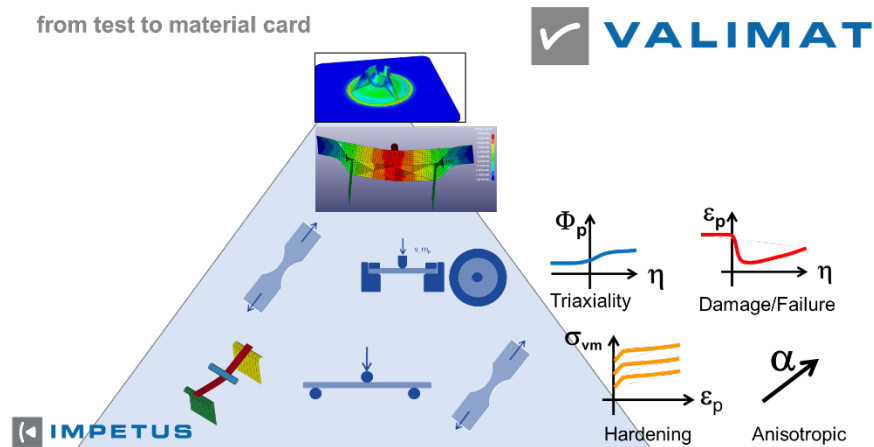

Fig.1: Characterization pyramid for IMPETUS™; from basic characterization up to final component validation.

Commonly Used Material Models for Plastics

LS-DYNA offers almost 300 different material models for all kind of material classes. For plastics especially in the automotive area three material models are commonly used:

***MAT_024** (and similar models ***MAT_081**, ***MAT_089**, ***MAT_123**, ...)

***MAT_124**

***MAT_187**

The typical possibilities of these three material models are summarized in table 1.

***MAT_024 - The workhorse** - As already mentioned before this is the default material model in crash simulations. It is an elasto-viscoplastic material. The material behavior is described using a simple J2 plasticity, meaning it has a cylindric von Mises yield surface (figure 2) and the plastic Poisson's ratio is 0.5 which is equivalent to a constant volume.

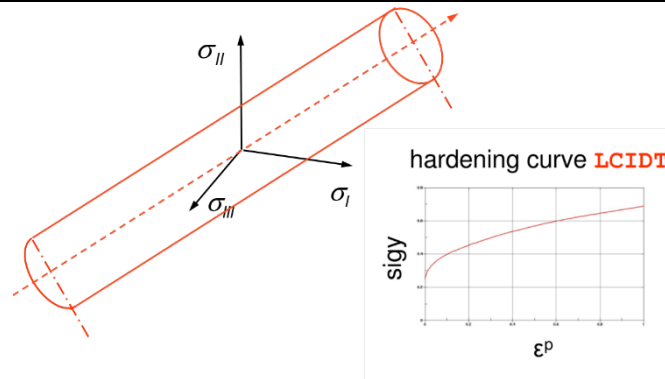

Fig.2: Von Mises yield surface in principal stress coordinates – well known cylinder

***MAT_124 - The hidden** - Like ***MAT_024** this material type is an elasto-viscoplastic material. But this material model can distinguish between the different behavior for tension and compression in plastic state. For this two von Mises cylinders are used, so it can be seen as a double ***MAT_024** (figure 3). New feature since R9.1 is the possibility of considering the visco-elasticity using a 6-term Prony series (figure 19).

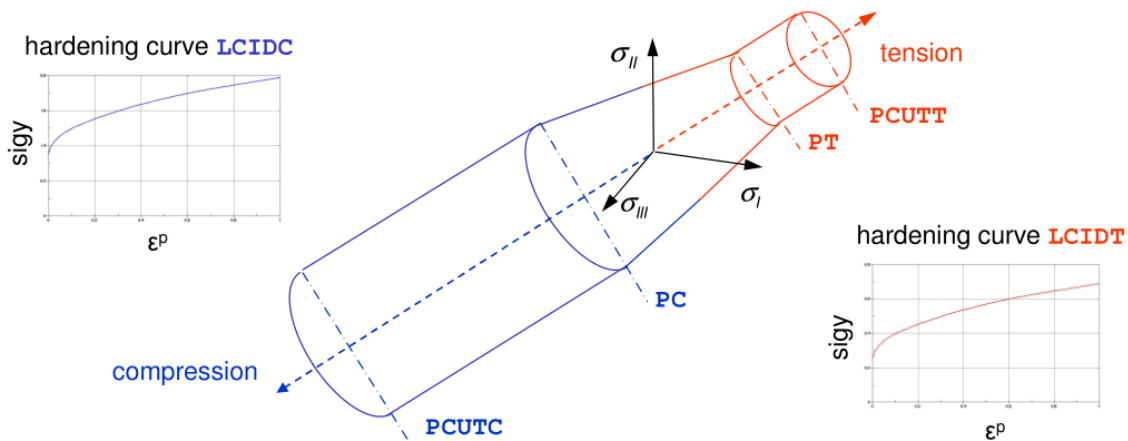

Fig.3: ***MAT_124** - yield surface [3]

***MAT_187 - The plastic expert** - This material model was especially developed for non-reinforced plastics, see more in the paper [4]. By defining stress-strain curves for tension, compression, shear and/or biaxial tension the yield surface is described using a

- von Mises cylinder (input: just tensile curve, analogue to ***MAT_024**)
- Drucker-Prager cone (input: tensile curve and a second curve)
- C-1 smooth yield surface - **RBCFAC=0** (input: tensile curve and two other curves)
- multi-linear yield surface - **RBCFAC≠0** (see figure 3)

Especially **RBCFAC≠0** can help promote convergence of the plasticity algorithm [5], meaning that this will also have effects on performance. Special feature of this material model is the capability of considering a plastic Poisson’s ratio lower than 0.5, which means a non-isochoric plastic behavior. This is typical for plastic materials as voids occur with progressive loading. Newest developments in R10.0 in the last year include also the possibility to consider visco-elasticity [6].

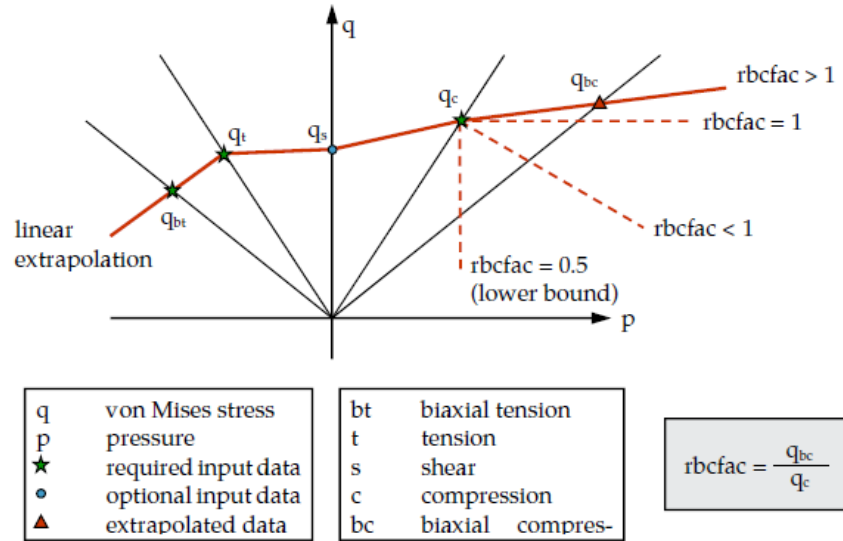

Fig.4: Von Mises stress as a function of pressure [5]

Table 1: Features of the three most common material models for plastics (failure not considered)

Material model	Yield surface	Visco-elasticity	Visco-plasticity	comp./tension symmetry	plastic Poisson's ratio
*MAT_024	von Mises	✗	✓	✗	0.5
*MAT_124	2x von Mises	✓ Pronyseries	✓	✓	0.5
*MAT_187	General over triaxiality	✓ Table	✓	✓	✓

Characterizing mechanical deformation behavior of plastics

In the Ph.D-thesis of F. Kunkel the mechanical behavior of Hostacom XBR 169G from LyondellBasell, a polypropylene with 16% talc as filler, which is used in automotive parts, was researched. For this material plates with a dimension of 80 x 80 x 2.5 mm were injection molded (figure 5, left) and test specimens in (W0) and perpendicular (W90) to the flow direction were milled out of these plates (figure 6). Then the mechanical characterization was carried out, tests like static and dynamic tensile test, static shear and static compression tests including a DIC (digital image correlation) were conducted. For comparison static and dynamic bending tests using IMPETUS™ without DIC were also performed and by using the reverse engineering method stress-strain curves were derived. Finally, the equivalent stress-strain results of both characterization methods were compared. [7]

Furthermore, the 4a mold (figure 5 right) was used for further investigation considering failure behavior and a final validation of the material card on a small component with typical plastics part geometry.

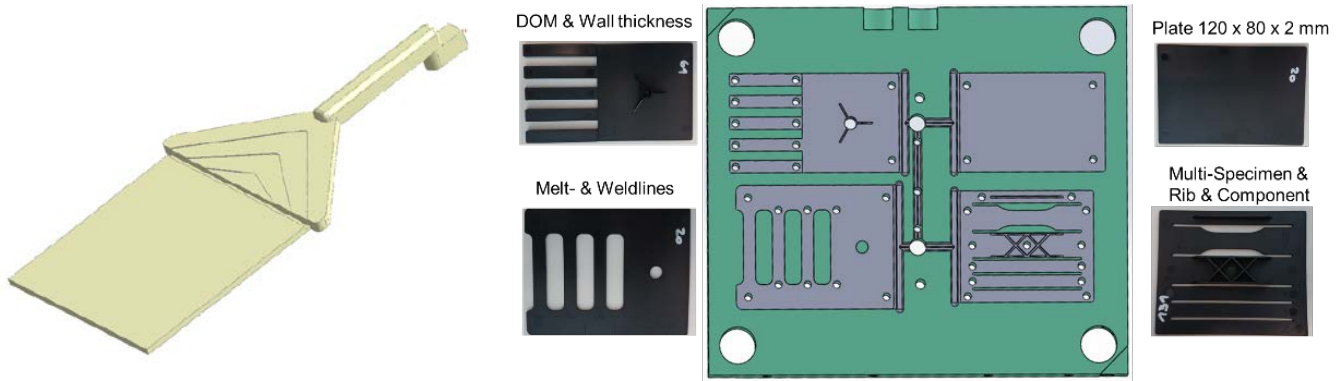

Fig.5: Injection molding: left – used mold in [7], right – used mold for failure evaluation and validation [8]

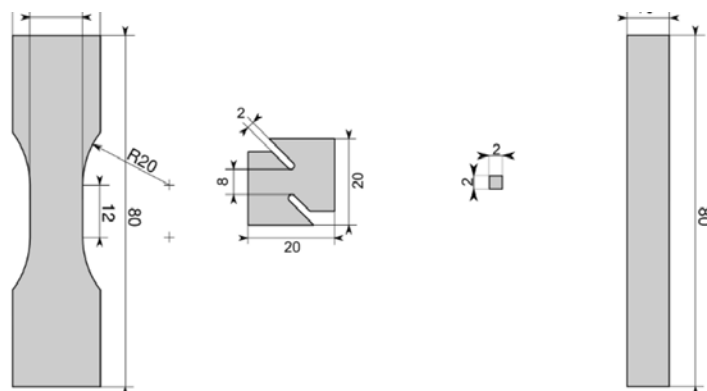

Fig.6: Milled out specimens [7]

The Old School – The idea behind is to conduct the material characterization as described in the material model. Therefore, typically in plane uniaxial tension, shear and compression tests are carried out. Generally, most of the engineers are familiar with tensile tests, these tests seem to be easy; therefore, tensile tests are often used to determine elasticity, plasticity and failure. Figure 7 shows the results based on the underlying DIC of the conducted tensile tests in [7]. The well-known material behavior of plastics can be seen, with an increasing test speed – meaning higher strain rates - the material gets more brittle. Furthermore, the measurements showed that the strain rate is increasing dramatically near the localization – which concludes that deriving the hardening curves of a material card is not just taking the measured and transformed “Von Mises stress-plastic strain” curves.

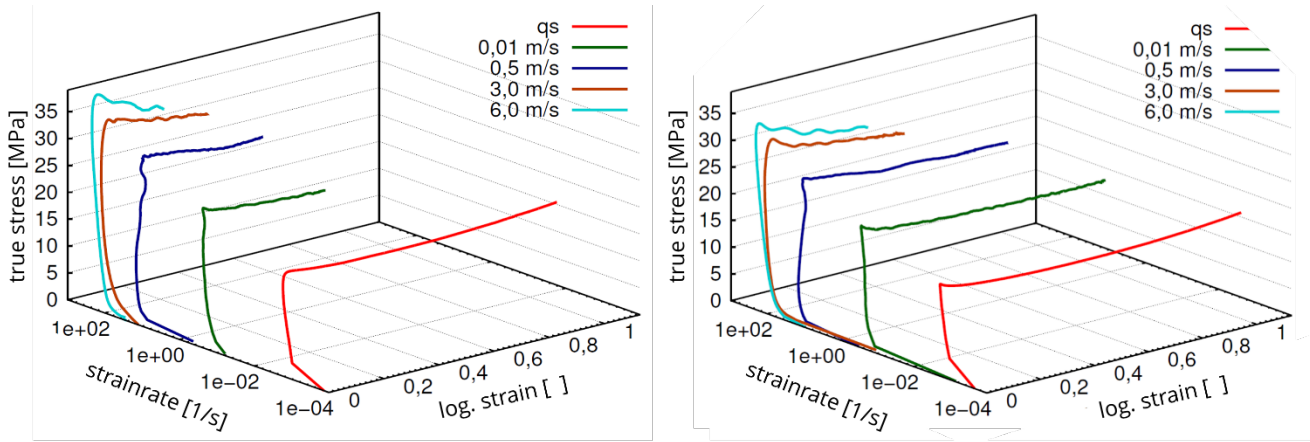

Fig.7: Quasi-static and dynamic tensile tests in W0 and W90 [7]

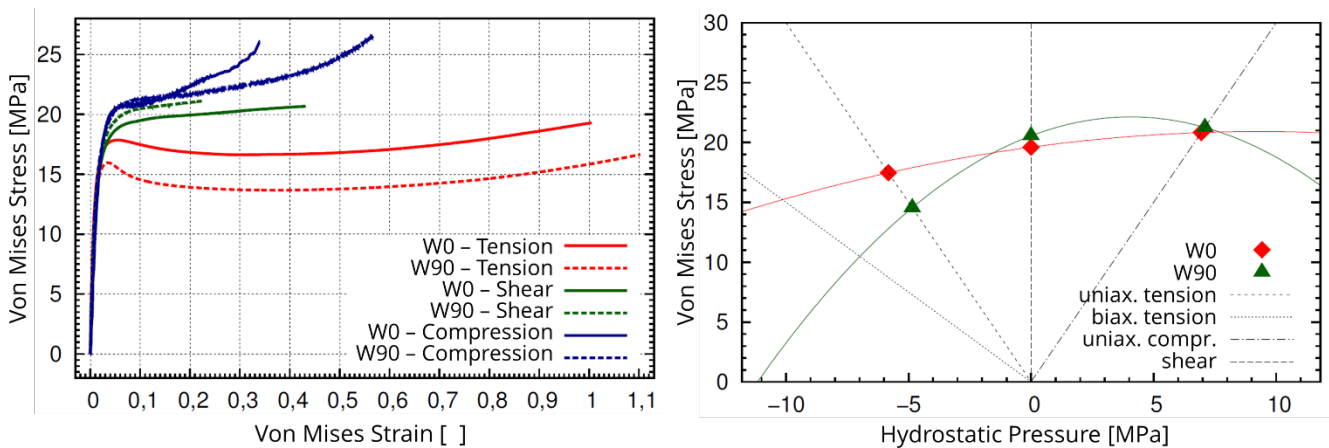

Fig.8: PP-T16 static tests at 23°, left - deformation behavior under different loading, right – yield surface at 0.1 von Mises strain [7]

In [7] also static shear and compression tests were carried out and the von Mises stress was evaluated as shown in figure 8 left. That can be also determined like a yield surface used in ***MAT_SAMP-1**, shown in figure 8 right. As already mentioned before, it's not the best choice to use this measured data directly for the hardening curves of a material card, neither strain rate - also in static case - nor triaxiality is constant during the test. Especially in case of uniaxial tension the triaxiality will increase with the increasing strain. To derive a good material card a reverse engineering procedure is needed to simulate the conducted tests.

Reverse Engineering – The material parameters are adapted iteratively until simulation and test fit with a minimum of deviation by using optimization software like LS-OPT. Parameter identification can be solved using mathematical optimization. In most cases the objective is to minimize the mismatch between two curves, typically a two-dimensional experimental target curve, e.g. a stress-strain curve or a force-displacement curve, and the corresponding computed curve extracted from a simulation. The computed curve depends on system parameters that can be varied, e.g. material constants.

To solve parameter identification problems, "Sequential Response Surface Method with domain reduction" is usually used. Figure 9 shows the principal result of characterizing the hardening behavior based on a three-point bending test of PP-T16. By each iteration the simulation curve fits the test curve better and the design space is becoming smaller. [9]

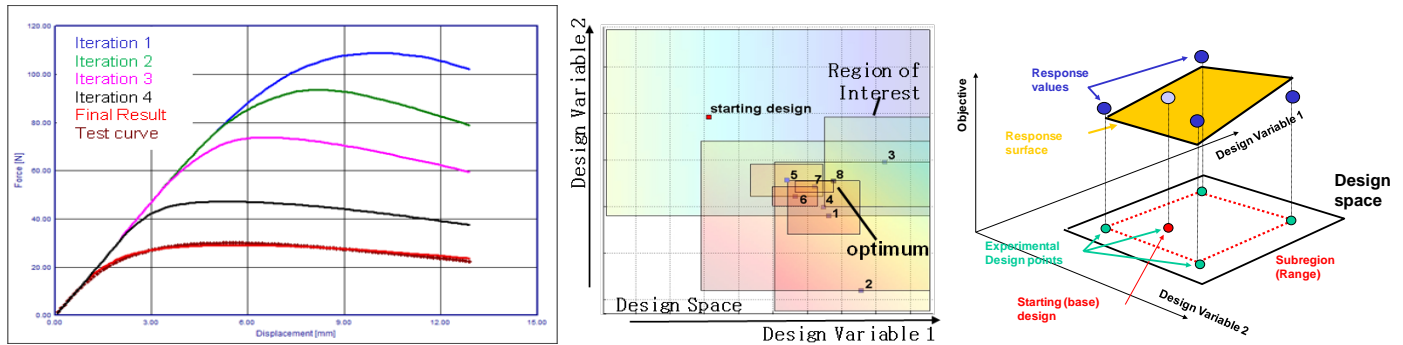

Fig.9: left - fitting of the simulation curve to the test curve (hardening behavior of a PP-T16; three-point bending);
right - reduction of the design space iteratively by reverse engineering [9].

IMPETUS™ the basic idea – About 10 years ago a total different approach was developed by 4a engineering GmbH, using simple three-point bending tests. Idea behind was to get hardening curves especially for plastics, that are

- representing an average between tension and compression behavior (figure 10),
- derived from loading the outer-surface as it happens in reality,
- loaded and unloaded at different velocities,
- a cost- and time efficient alternative to classical test methods.

Unfortunately, there is no possibility to directly determine the outer-surface stress of the obtained force-displacement curves – also a reverse engineering procedure is needed to derive the hardening curves for a material card like ***MAT_024**. Therefore, 4a engineering GmbH is offering a testing device IMPETUS™ for dynamic impact velocities, see figure 11, as well as a software solution VALIMAT™ (former 4a IMPETUS™), that provides the user a workflow from test to material card by

- including reverse engineering procedure,
- using LS-DYNA and LS-OPT,
- using parameterized material laws for hardening as well as for more complex topics.

More details on the development history of IMPETUS™ over the last years can be found in [10][11][12]. For the investigated material the measured bending test results are shown in figure 12. To extract a material card from this measurement data, VALIMAT™ offers an automatic workflow. Figure 13 shows this exemplary for ***MAT_024**, starting with determining

- elasticity at lowest dynamic impact velocity,
- plasticity also at lowest dynamic impact velocity,
- finally, the viscous behavior of the plastic domain.

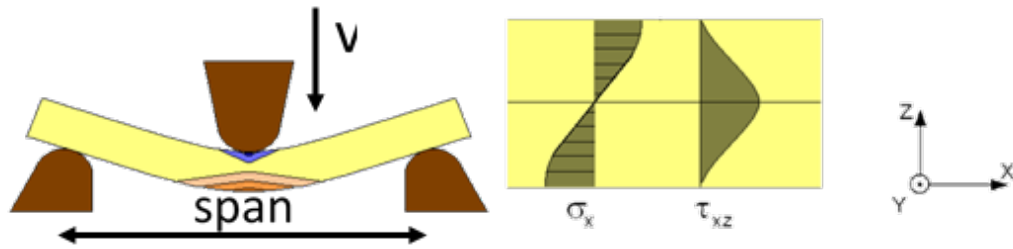

Fig.10: Stress distribution in the three-point bending test [12]

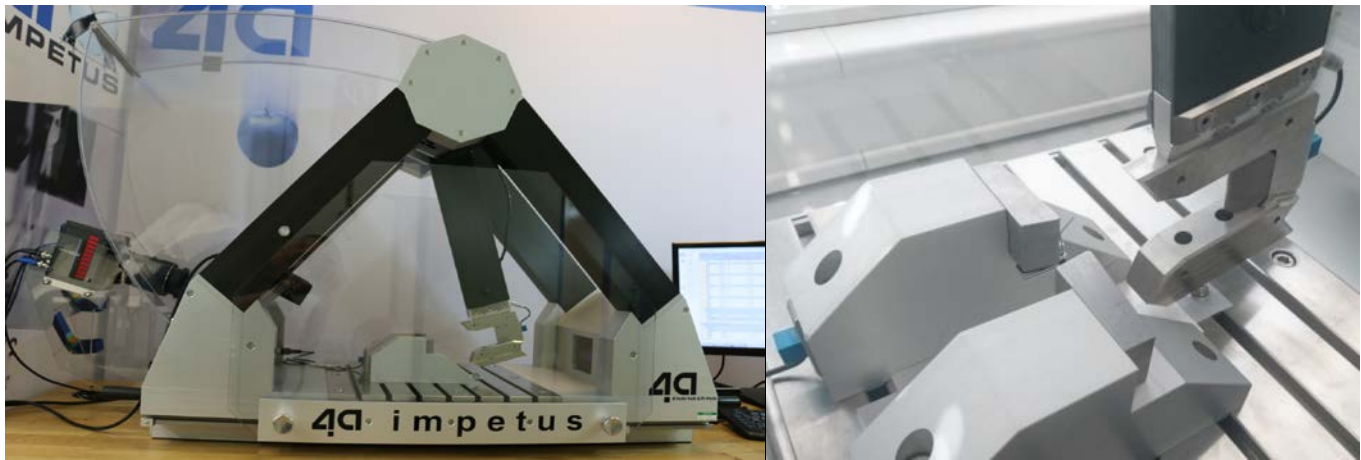

Fig.11:left - actual version of IMPETUS™, right - test setup bending

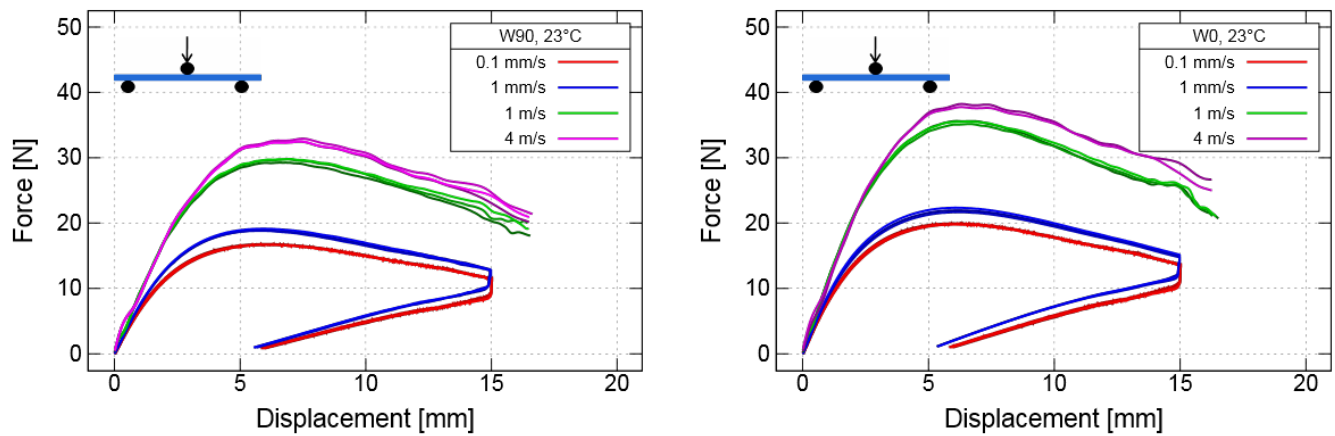

Fig.12: Test results achieved with IMPETUS™: left - 3-point-bending W90; right - 3-point-bending W0

VALIMAT™ result for *MAT_024 – finally the workflow results in the found parameters for the used material law – e.g. analytical equation describing the hardening curve – and a ready-to-use material card for LS-DYNA, shown exemplary in figure 14 left. To compare the material behavior of the investigated PP-T16 under different load cases as well as the different approaches “old school” and “bending based” the von Mises stress at 10 % equivalent strain is plotted over the strain rate. In figure 14 right we can see the expected behavior, bending lies between the compression and tension stress level. Interesting is the same slope – stress over strain rate – in tension and bending case.

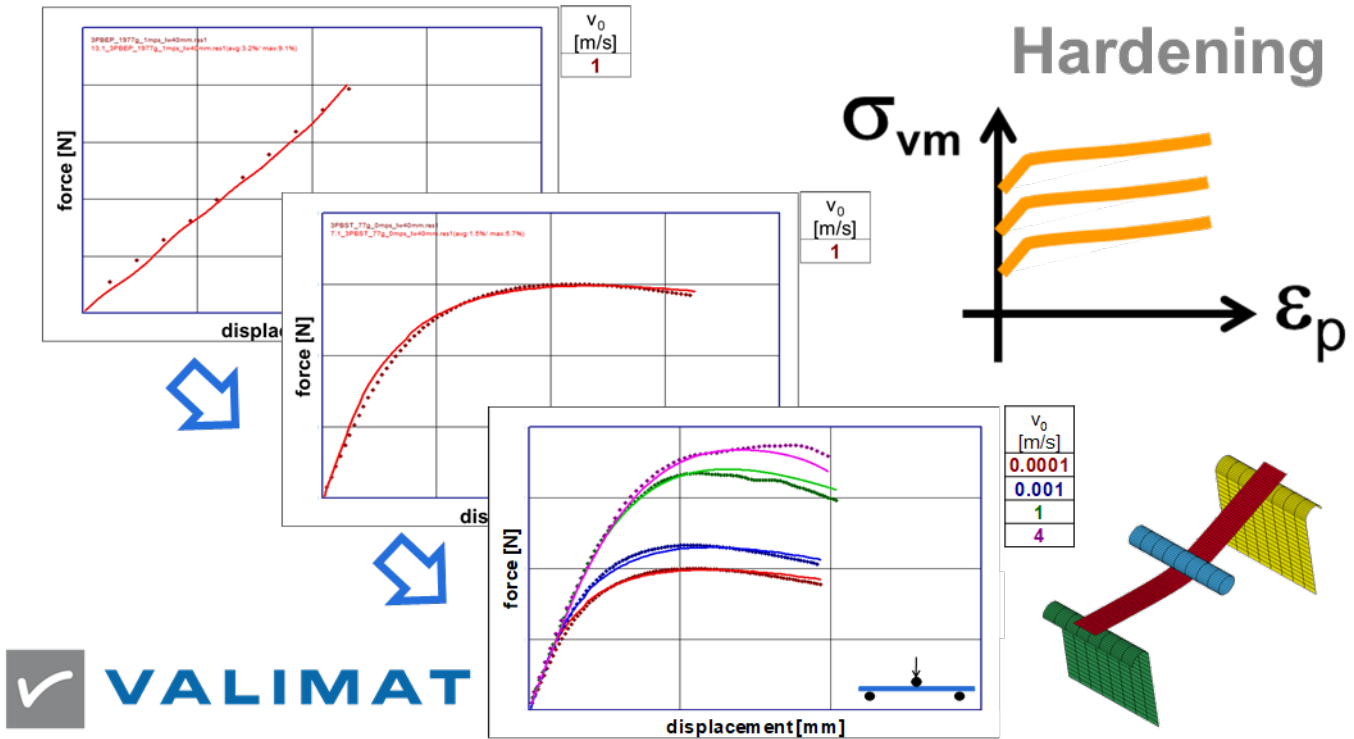

Fig.13: Workflow to generate ***MAT_024** out of bending tests.

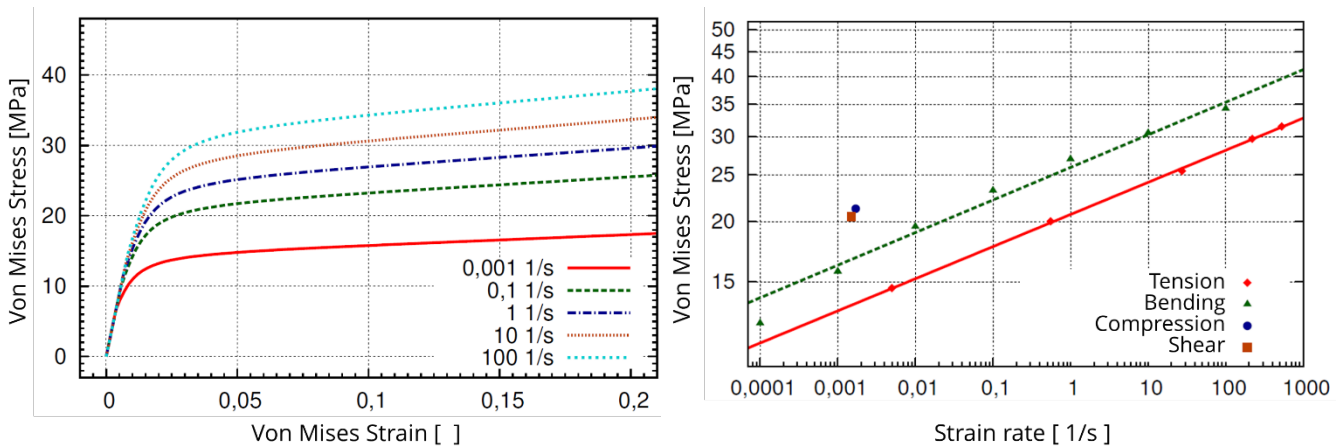

Fig.14: W90, left – resulting hardening curves derived from bending tests, right - comparison between different load cases; for more details see [7]

IMPETUS™ new requirements – In the last years further test methods for IMPETUS™ were developed to characterize special material effects of plastics like compression/tension asymmetry or failure (figure 15). These test methods are easy and fast to perform and failure at different triaxialities can be specifically investigated, test results for the investigated PP-T16 are shown in figure 16. Also, a high-speed-camera can be implemented and triggered in IMPETUS™ (figure 15, right). This allows the visualization of dynamic behavior of the material during test (crack initiation and propagation in detail, figure 17) and a direct correlation to the measurement signals [12].

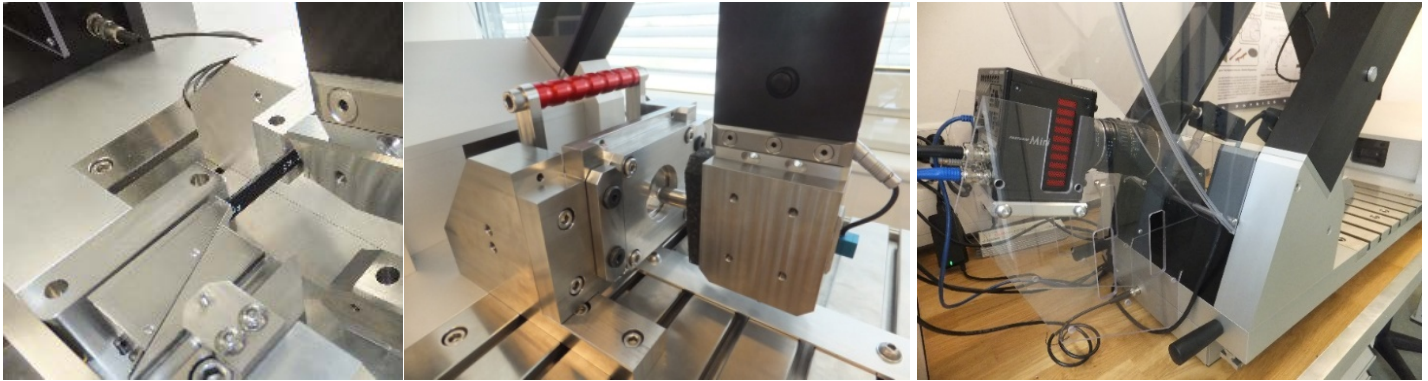

Fig.15: Test setups in IMPETUS™: left - dynamic bending tensile test; middle - dynamic puncture test; right - implementation of a high-speed camera including triggering and control by IMPETUS™

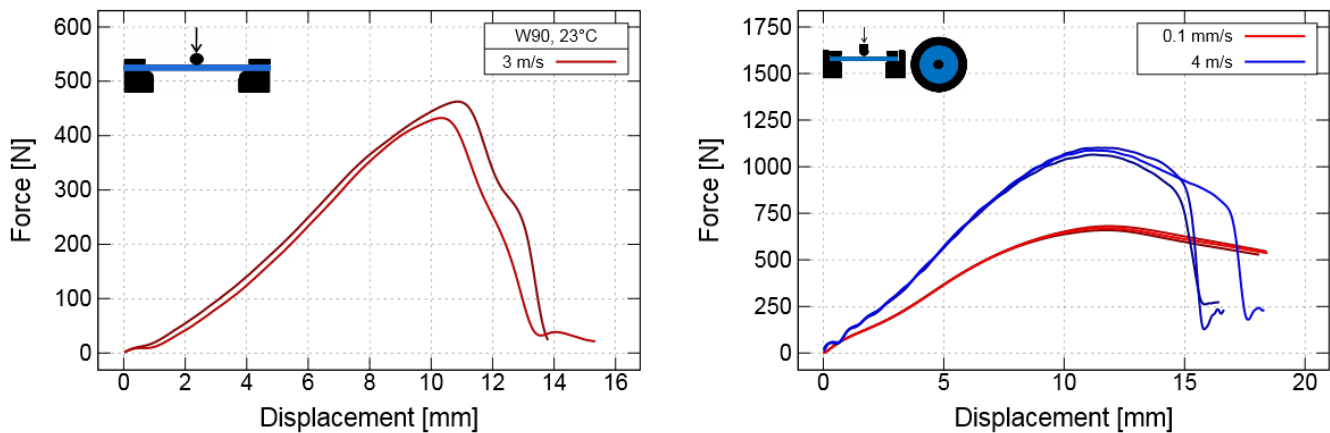

Fig.16: Test results in IMPETUS™: left - dynamic bending tensile test; right – static and dynamic puncture test

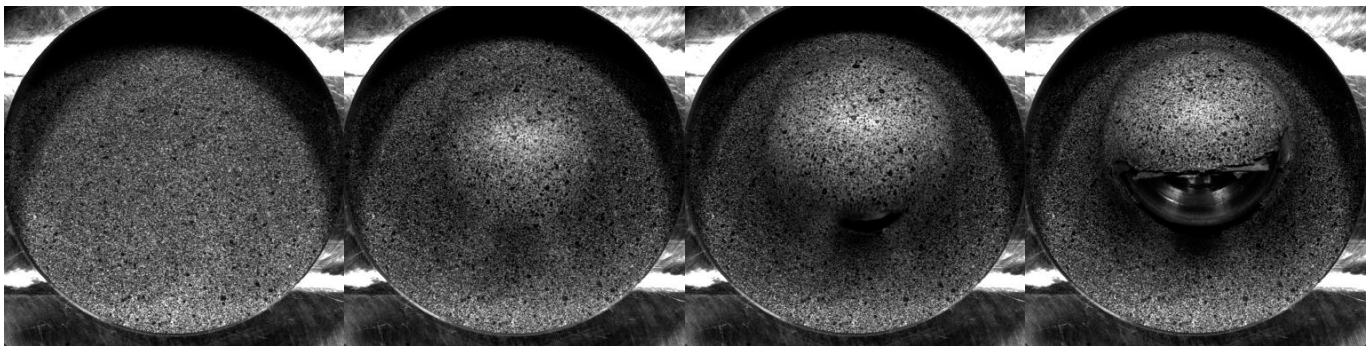
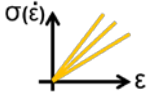
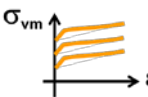
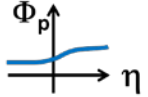
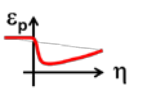

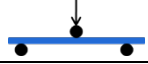
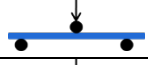





Fig.17: Pictures of a high-speed video of a dynamic puncture test at different time steps: beginning – penetration of the plunger – first crack – crack propagation

Depending on the test type different behavior of plastics can be captured (table 2). For the current standard at 4a for plastic material the 3-point bending test is the base of all material characterizations. Using this test at various velocities a simple ***MAT_024** can be modeled. For a more sophisticated material model further tests must be done. So, the user is able to get all the necessary measurement data for his chosen material model by setting up an appropriate test plan. This leads to the typical characterization pyramid shown in figure 1.

Table 2: Measurement results in dependence of the test type

Test type		Visco-elasticity 	Hardening & Viscop. σ_{vm} 	Triaxiality Φ_p 	Damage / Failure ϵ_p 	Anisotropy α 
3-point bending		✓	✓		~	✓
Cyclic 3-pt bend.					✓	
Tension bending				✓	✓	
Puncture test					✓	
Tensile test				✓	✓	

Additionally, external tests conducted on universal testing and servo-hydraulic machines or on fall energy driven devices like fall towers including DIC can be imported in VALIMAT™ and used for the material characterization process. Using VALIMAT™ the user can also define his own characterization pyramid, depending on what tests are available and/or have more relevance from user’s and /or material’s perspective.

Material card generation – strain rate dependent yield behavior

For the investigated material we used the following material models (**MAT_024*, **MAT_124*, **MAT_187*) to describe the material behavior based on our bending approach in VALIMAT™. It is obvious that the results are quite comparable, meaning that all three material models can reproduce the 3-point-bending results (figure 18 left). If you take a look at the results of the dynamic tension bending test, which is dominated by tension behavior (figure 18 right), it is clearly visible that **MAT_024* can’t reproduce this test as it doesn’t distinguish between tension and compression.

As it can be seen in figure 18 there is a discrepancy between measurement and simulation result for the low velocity in the elastic range. New features in LS-DYNA can consider this typical viscoelastic material behavior of thermoplastics. Figure 19 (left) shows the implementation of the visco-elasticity for **MAT_124* as Prony-series, figure 19 (right) shows a comparison of **MAT_187* with and without using the visco-elasticity. The better matching in the elastic range between measurement and simulation for the quasi-static velocity is obvious.

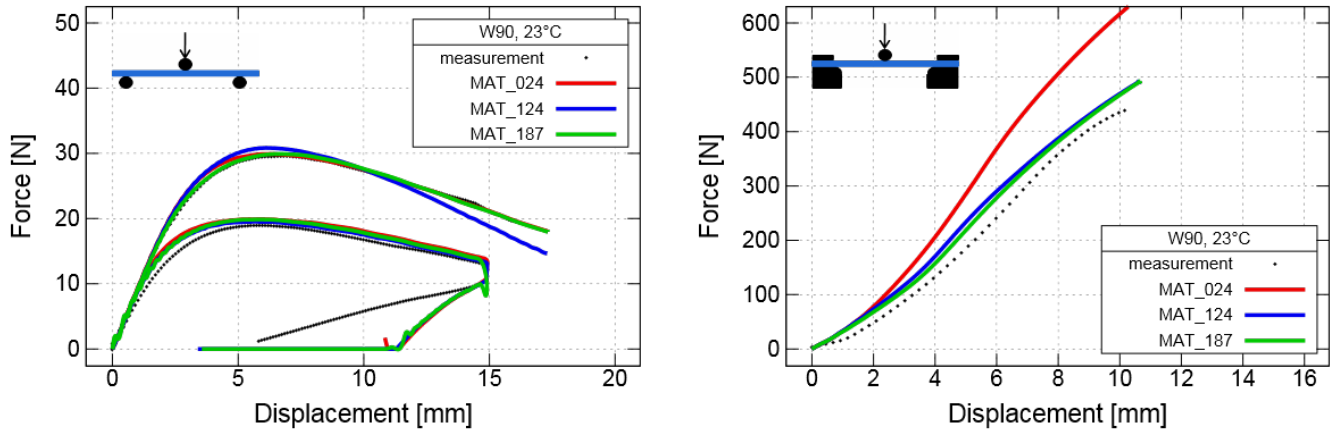

Fig.18:left - results for 3-point-bending at 2 velocities (quasi-static and dynamic) for the three material models; right - results for dynamic tension bending test for the three material models

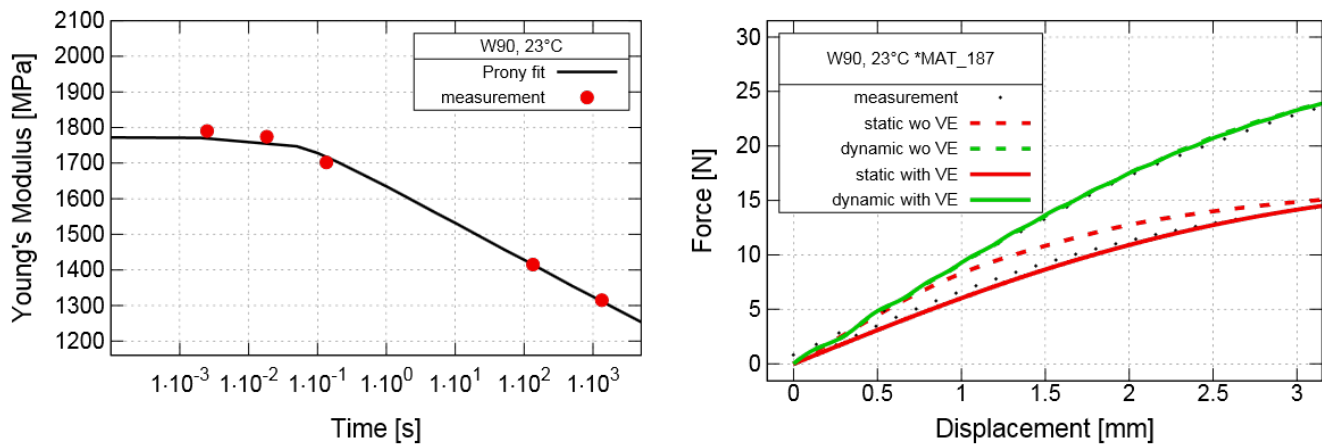

Fig.19:left - 6-term Prony fit for measured Young's moduli to use in *MAT_124; right - comparison for *MAT_187 with and without considering visco-elasticity for 3-point-bending at 2 velocities

Damage and Failure modeling

After modeling the yield behavior, damage and failure can be included in the material card. LS-DYNA offers many material models for plastics that have an implemented damage/failure modeling. The most commonly used failure models are implemented in VALIMAT™. This includes simple (“constant” plastic failure strain) up to highly complex models (plastic failure strain in dependency of strain rate and triaxiality, figure 20, right) with access to different failure models (Johnson Cook, Xue-Wierzbicki, Mohr-Coulomb, etc.), see figure 20, left. The significant inputs for the chosen failure model are accessible over the design variables (figure 20, right). So, an easy failure modeling and optimizing within VALIMAT™ is possible. Table 3 gives a short overview of the possible failure settings for these three common plastics models.

Table 3: Included failure features of the three most common material models for plastics

Material model	simple (plastic failure strain)	Integrated failure routine	*MAT_ADD_EROSION (GISSMO or DIEM)
*MAT_024	✓	✗	✓
*MAT_124	✓	✓	✓
*MAT_187	✓	✓	✓

The image shows two parts of the VALIMAT software interface. On the left is the 'Material behaviour' settings panel, and on the right is a 'design variables' panel.

Material behaviour settings (left):

- Material source: Implemented
- Elasticity: Linear isotropic elastic
- Plasticity: Yes
- Failure/Damage: Damage
- Material card: *MAT_SAMP-1 (*MAT_187)
- Materialcardcase: pressure dependent (Raghava)
- Damage/Failurecase: Add Erosion DIEM (circled in red)
- Materialcard id: None
- Density: plastic strain
- Plasticity: Add Erosion
- Function (Hardening, Elastic curve form): Add Erosion DIEM (circled in red)
- Curve 1: Add Erosion GISSMO
- Curve 2: scale curve 1
- Strain range upto: 1
- Sampling points: 100
- Bias factor: 10
- Strain rate dependency: Table
- Strain rate dependency: Johnson Cook
- Fracture: Damage
- Ductile Damage Settings: 4a piecewise linear (circled in red)
- lower triax value: -0.99
- upper triax value: 0.99
- step size triax: 0.33
- Shear Damage Settings: None
- FLC Damage Settings: None
- Strainrate Settings: Johnson Cook
- Postfracture: Fracture Energy (TRAX)

Design variables (right):

- Triaxiality (Group 51):**
 - xf_NUM...: 0.75 ✓
 - fd_BC: 2.0 ✓
 - fd_C: 2.0 ✓
 - fd_SHC: 2.0 ✓
 - fd_SHT: 0.1 ✓
 - fd_T: 0.1 ✓
 - fd_BT: 0.2 ✓
- Strain rate dependency (Group 52):**
 - fv_scale: 0.0 ✓
 - fv_epspkt: 0.001 ✓
 - fv_epsp...: 1000.0 ✓
- Post failure (Group 53):**
 - pf_QBC: 0.05 ✓
 - pf_QC: 0.05 ✓
 - pf_QSHC: 0.05 ✓
 - pf_QSHT: 0.05 ✓
 - pf_QT: 0.05 ✓
 - pf_QBT: 0.05 ✓

Fig.20:left - modeling failure in VALIMAT™; right - according design variables for the chosen failure model

Thermoplastics are mostly ductile and show no measurable failure under compression and shear, so failure criteria can be modeled especially for the triaxiality above 0.33. For failure lower than the triaxiality of 0.33 just assumptions can be made, figure 21 shows the resulting failure surface of a ductile PC/PET which was researched in detail [13].

The Gurson and GISSMO model derived from metal models consider this fact also by assuming a high plastic failure strain at negative triaxialities [14].

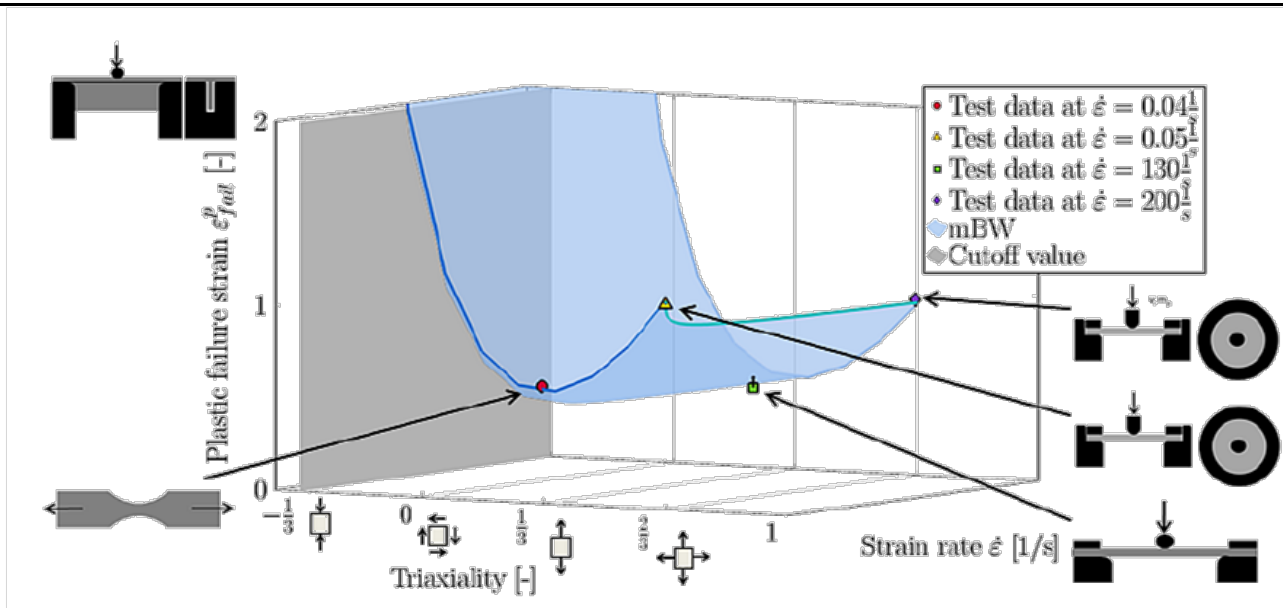

Fig.21: Failure surface derived from detailed research of a PC/PET [13]

Cyclic bending or tensile tests help to determine the correct yield point for the material on the one hand. On the other hand, they give quite good information about the damage development with ongoing loading. These results can be included in the material card to detail the material behavior. Figure 22 shows the result of a cyclic 3-point-bending test. With each cycle the loading is increased and damage grows. The test results can be evaluated in VALIMAT™ and used for modeling the material behavior.

In [15] the damage function in dependence of the plastic Poisson's ratio is described, meaning that the void volume growth that is linked to the ductile damage can also be measured in transversal strains.

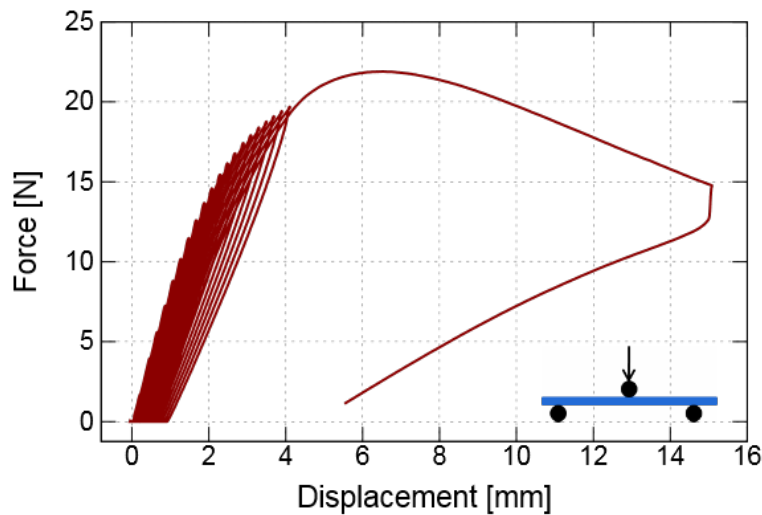

Fig.22: Cyclic 3-point-bending test in VALIMAT™ for determining the yield point and damage development.

Validation

To model damage/failure the keyword `*MAT_ADD_EROSION` with the GISSMO model [5] was added to `*MAT_187` and adapted to the test curves. In figure 23 the models of the test specimens are displayed while figure 24 shows a comparison of test and simulation results using the `*MAT_187` material card for various tests.

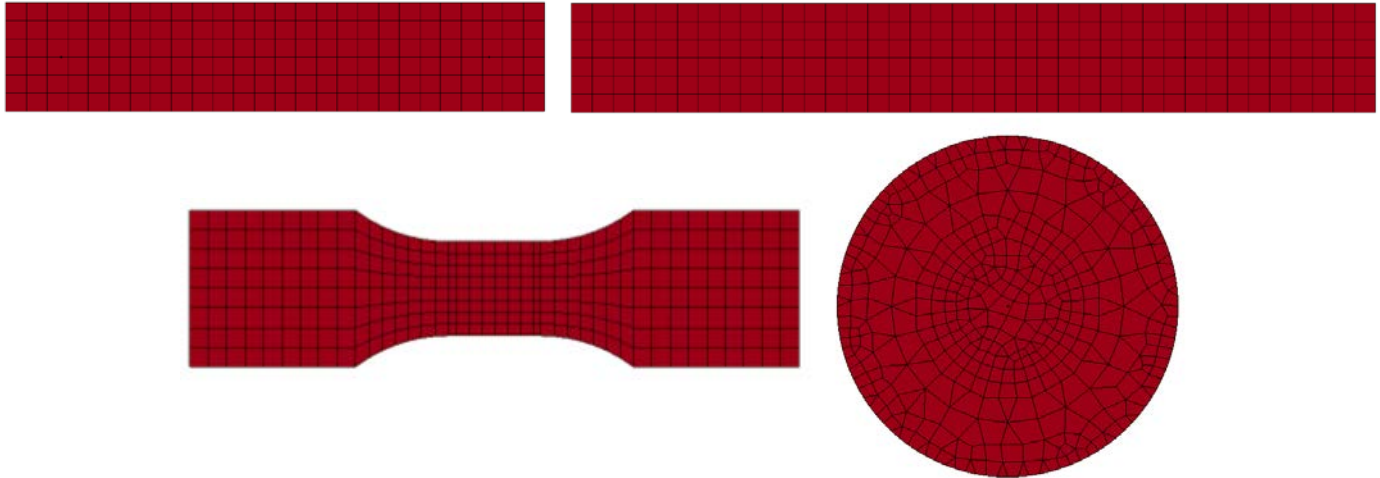

Fig.23: Models of the test specimens for 3-point-bending (top left), dynamic bending tensile (top right), tensile (bottom left) and puncture test (bottom right)

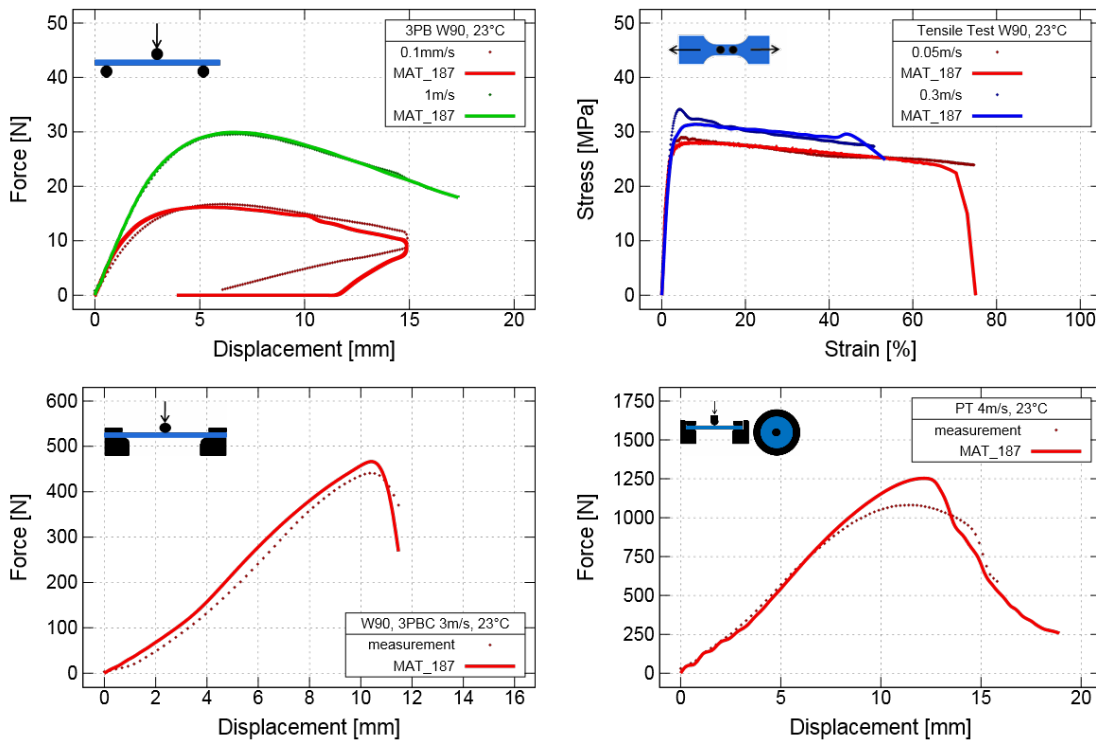

Fig.24: Comparison of test and simulation results for the generated material card for bending tests (top left); tensile tests (top right); dynamic bending tensile test (bottom left) and dynamic puncture test (bottom right)

A final validation of the complete material card was performed for a dynamic puncture test on a plate with a boss using IMPETUS™. Figure 25 shows the good conformity of simulation and test curves. Figure 26 shows a photo of the part taken by a high-speed camera and a comparison to the simulation result.

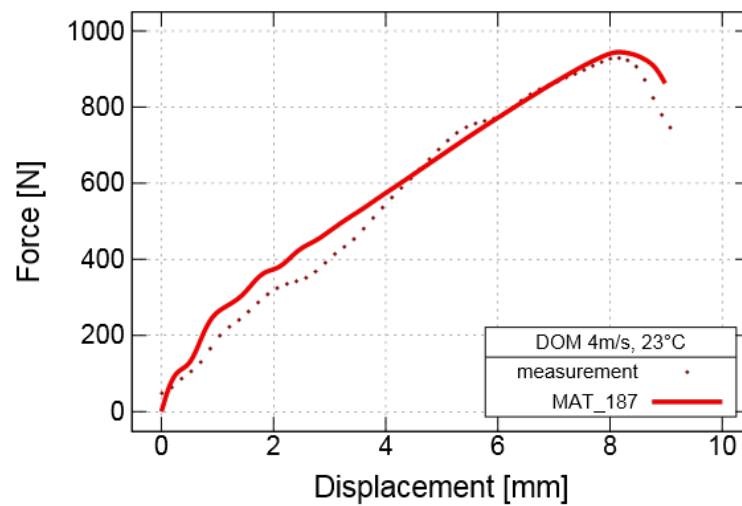

Fig.25: Comparison of test and calculation results for a part characterized by ***MAT_187** and failure model ***MAT_ADD_EROSION**

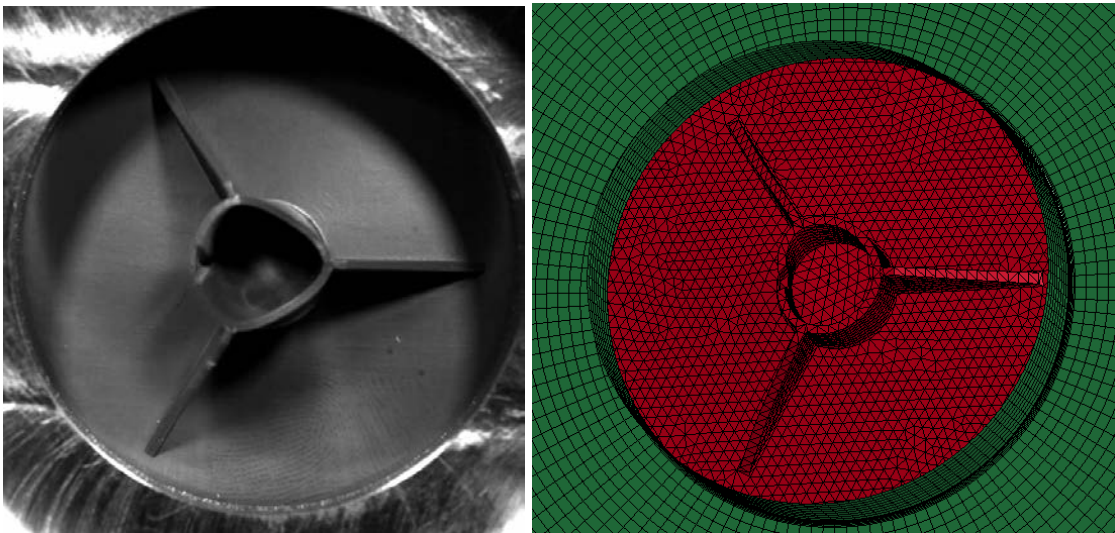

Fig.26: Comparison of the real part (left) and the simulation part (right) after loading in a puncture test, beginning of failure is matched quite well

Outlook

To fulfill the permanent rising demands on the material characterization IMPETUS™ and VALIMAT™ are continuously improved. Latest development is a dynamic tensile test performable in IMPETUS™ (figure 27). By using an optical measurement like DIC (figure 28) an analogue setup to the dynamic tensile test on a servo-hydraulic machine can be performed with the advantage of a much easier setup and handling.

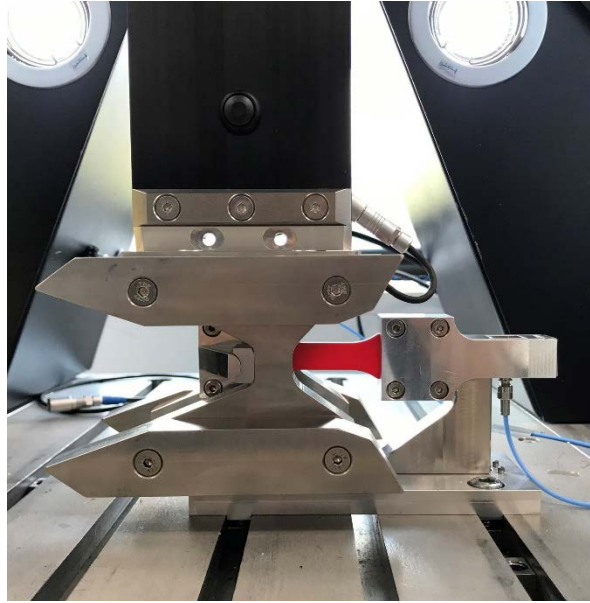

Fig.27: Forthcoming dynamic tensile test in IMPETUS™

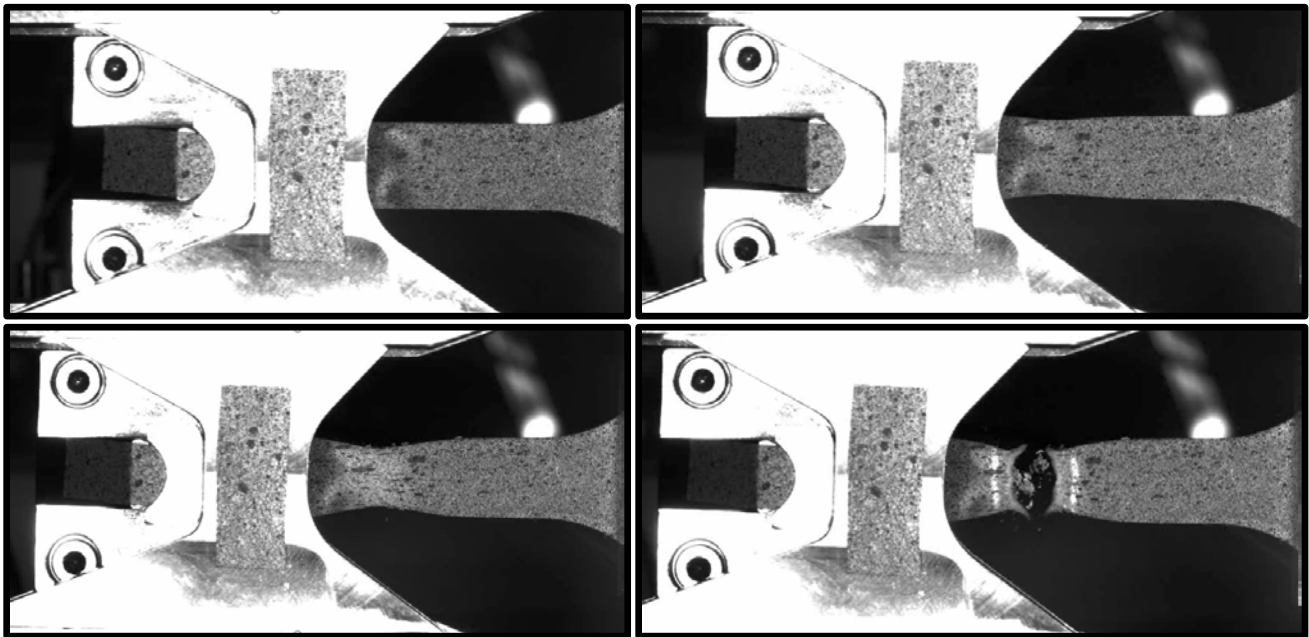

Fig.28: Optical measurement on dynamic tensile test in IMPETUS™

VALIMAT™ of course is also updated with new features like the automatic DIC integration, which will soon be available, or the implementation of new user defined test specimens (figure 29). These test specimens can be either used for fitting the failure surface (triaxiality, Lode angle) on additional grid points or for a final validation of material cards on a component level. More information and details can be found in [16].

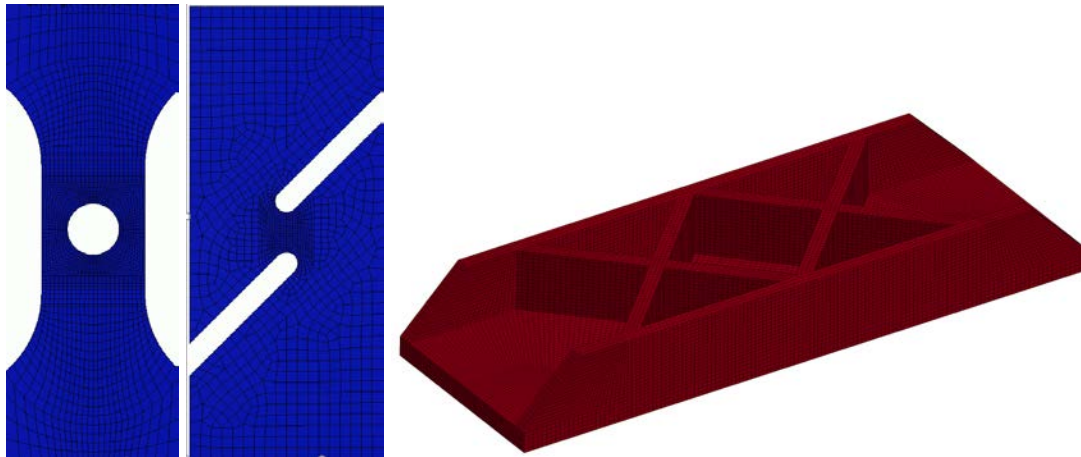

Fig.29: Some new test specimens supported in VALIMAT™; left: tensile bar with hole; middle: shear test specimen; right: XX-rib component [16]

Summary

IMPETUS™ is an efficient reliable possibility for characterizing materials, especially unreinforced as well as fiber reinforced thermoplastics. Using static and dynamic 3-point-bending tests simple material cards (***MAT_024**) are generated reasonable and quickly by VALIMAT™. If the material shows a tension/compression asymmetry (typical for plastics) the simple material model is limited, so more complex material models (e.g. ***MAT_124** or ***MAT_187**) are needed. For this further testing methods using IMPETUS™ have to be performed (e.g. puncture test, dynamic bending tensile test). The intelligent software solution VALIMAT™ is then used to generate the material cards based on the IMPETUS™ test methods. For this a workflow was configured to get almost automatically the parameters for even complex material cards like ***MAT_187**.

If necessary failure can then be included in the material card. The most popular failure models from simple to complex damage/failure are available in VALIMAT™ and so failure can be modeled quite easily.

Various measurement results for a PP-T16 (Hostacom XBR169) using IMPETUS™ were shown. These results were used to generate these three common material cards for plastics.

They were then compared to each other, also the advantages and differences of the material models were shown, new features in LS-DYNA® R10 like the visco-elasticity were discussed. Finally a failure model was then added to ***MAT_187** and validated on a demonstrator part. The simulation and measurement results matched quite well.

IMPETUS™ and VALIMAT™ offer all needed requirements to describe the yield and failure behavior of unreinforced as well as reinforced thermoplastics close to reality and guarantee an accurate material modeling.

References

- [1] P. Reithofer, A. Erhart, A. Fertschej, S. Hartmann, B. Jilka, „*MAT_4A_MICROMECH - Theory and Application Notes”, 11th European LS-DYNA Conference Salzburg, 2017.
- [2] P. Reithofer, A. Haufe, V. Effinger, M. Rollant, M. Fritz, „Validation and Material Modelling of Plastics”, 8th European LS-DYNA Conference Straßburg, 2011.
- [3] A. Haufe, V. Effinger, „Material Modelle in LS-DYNA“, Kunststoff Info-Tag, Filderstadt 2013.
- [4] P. DuBois, St. Kolling, M. Feucht, A. Haufe, „A semianalytical model for the simulation of polymers“, LS-DYNA-Forum, Bamberg, 2005.
- [5] N.N., „LS-DYNA Keyword User’s Manual – Volume II”, r.9384 from 01-11-2018.
- [6] P. DuBois, M. Feucht, J. Irslinger, T. Erhart, „Implementation of a VE-VP Material Law for the Simulation of Energy Absorbing Thermoplastic Components“, European LS-DYNA-Forum, Salzburg, 2017.

- [7] F. Kunkel, „Zum Deformationsverhalten von spritzgegossenen Bauteilen aus talkumgefüllten Thermoplasten unter dynamischer Beanspruchung“, PhD.-Thesis, Magdeburg 2017.
- [8] A. Fertschej, P. Reithofer, M. Rollant, „Interaction of solver settings / idealization / material card for different explicit solvers on bending load cases“, CAE Grand Challenge, Hanau, 2016.
http://impetus.4a.co.at/images/downloads/events/23_rep_16042001_afer_pr_mr_gga_CAEGrandChallenge2016-2.pdf
- [9] <https://www.carhs.de/en/companion-poster/product/automotive-caecompanion-20182019-digital-pdf.html?sprache=Englis>, pp. 77-79.
- [10] M. Fritz, „Ermittlung von Werkstoffparametern für die Fahrzeug-Crashsimulation aus Biegeversuchen“, Diploma-Thesis, Leoben 2003.
- [11] P. Reithofer, A. Fertschej, M. Rollant, “4a IMPETUS™ (PART 1): Dynamic Material Characterization of Plastics – Development in the Past 10 Years”, 14th German LS-DYNA Conference Bamberg, 2016.
http://impetus.4a.co.at/images/downloads/events/29_rep_16110401_pr_afer_mr_gga_4aimpetusPart1_gesamt.pdf
- [12] A. Fertschej, P. Reithofer, M. Rollant, “4a IMPETUS™ (PART 2): innovations – test methods, MAT_SAMP-1, anisotropy, composites and more”, 14th German LS-DYNA Conference Bamberg, 2016.
http://impetus.4a.co.at/images/downloads/events/28_rep_16110401_afer_pr_mr_gga_4aimpetusPart2_gesamt.pdf
- [13] H. Staack, D. Seibert, H. Baier, „Application-oriented Failure Modeling and Characterization for Polymers in Automotive Pedestrian Protection”, Complas XIII, Barcelona, 2015.
- [14] J. Effelsberg, A. Haufe, M. Feucht, F. Neukamm, P. DuBois, „On Parameter Identification for the GISSMO Damage Model”, LS-DYNA-Forum, Ulm, 2012.
- [15] M. Nutini, M. Vitali, „Characterization of Polyolefins for Design under Impact: from True Stress/Local Strain Measurements to the F.E. Simulation with LS-DYNA Mat. SAMP-1”, 7. LS-DYNA Forum, Bamberg 2008.
- [16] B. Jilka, M. Rollant, „IMPETUS™ - Nicht immer zieht es sich in die Länge“, 4a Technologietag, Schladming 2018
http://impetus.4a.co.at/images/downloads/events/40_pres_18032001_bj1a_pr_afer_eng_TT18_ZIEHT.pdf