

Crash Testing and Simulation of a Cessna 172 Aircraft: Hard Landing Onto Concrete

Karen E. Jackson
NASA Langley Research Center
Hampton, VA

Edwin L. Fasanella
National Institute of Aerospace
Hampton, VA

Abstract

A full-scale crash test of a Cessna 172 aircraft was conducted at the Landing and Impact Research Facility at NASA Langley Research Center during the summer of 2015. The purpose of the test was to evaluate the performance of Emergency Locator Transmitters (ELTs) that were mounted at various locations in the aircraft and to generate impact test data for model validation. A finite element model of the aircraft was developed for execution in LS-DYNA[®] to simulate the test. Measured impact conditions were 722.4-in/s forward velocity and 276-in/s vertical velocity with a 1.5° pitch (nose up) attitude. These conditions were intended to represent a survivable hard landing. The impact surface was concrete. During the test, the nose gear tire impacted the concrete, followed closely by impact of the main gear tires. The main landing gear spread outward, as the nose gear stroked vertically. The only fuselage contact with the impact surface was a slight impact of the rearmost portion of the lower tail. Thus, capturing the behavior of the nose and main landing gear was essential to accurately predict the response. This paper describes the model development and presents test-analysis comparisons in three categories: inertial properties, time sequence of events, and acceleration and velocity time-histories.

Introduction

During the summer of 2015, NASA Langley Research Center conducted three full-scale crash tests of Cessna 172 (C-172) aircraft at the Landing and Impact Research Facility (LandIR) [1, 2]. The first test represented a flare-to-stall emergency or hard landing onto a rigid surface. The second test represented a controlled-flight-into-terrain (CFIT) with a nose down pitch attitude of the aircraft, which impacted onto soft soil [3]. The third test also represented a CFIT with a nose up pitch attitude of the aircraft, which resulted in an initial tail strike condition. Test 3 was also conducted onto soft soil. These crash tests were performed for the purpose of evaluating the performance of Emergency Locator Transmitters (ELTs) and to generate impact test data for model validation. LS-DYNA [4, 5] finite element models were generated to simulate the three test conditions. The focus of this paper is to present test-analysis results for Test 1.

The crash test series conducted in the summer of 2015 generated data for use in updating the performance specifications for the next generation of ELT systems. ELT systems are present on all General Aviation (GA) aircraft and are intended for use in an emergency situation, such as a crash landing. The ELT system is designed to automatically sense a crash event and to transmit a distress signal to Search and Rescue personnel, who are dispatched to provide assistance. ELT systems must be designed to work in a wide range of scenarios; consequently, three different impact conditions were selected to be replicated at the LandIR facility. Each of the C-172 test articles contained 4 or 5 individual ELTs that were mounted throughout the airframe interiors prior to the crash tests.

The Cessna 172 Skyhawk is a four-seat, single engine, high-wing airplane, manufactured by the Cessna Aircraft Company. More Cessna 172s have been built than any other aircraft and the first

production models were delivered in 1956. As of 2015, Cessna, and its partners, have built more than 43,000 airframes. The wide availability of these aircraft was one reason that they were selected for the test series. A second reason for the selection was because research showed no correlation between airplane make or model and ELT performance, indicating that the C-172 was as likely a candidate for the test series as any other aircraft. It is also noted that NASA had previously conducted a series of crash tests using C-172 aircraft in the 1970's [6, 7] and these tests helped to guide the development of the lifting hardware used in the current tests.

This paper will provide a brief description of the first C-172 full-scale crash test (Test 1), a summary of the finite element model development, and test-analysis comparisons in three categories: inertial properties, time sequence of events, and acceleration and velocity time-history responses.

Test Description

The C-172 aircraft used for the first crash test was built in 1958 and was current on its annual inspection. This aircraft was flying as late as the winter of 2014, before being transported to NASA Langley. A pre-test photograph of the C-172 aircraft is shown in Figure 1. The aircraft contained two crew seats, two Hybrid II 50th percentile Anthropomorphic Test Devices (ATDs), an onboard data acquisition system (DAS) box, four ELTs that were mounted throughout the cabin, and ballast weights to represent fuel loading in the wings. The total weight of the aircraft was approximately 2,000-lb. The left side of the aircraft was painted white and 1-in.-diameter black dots were added to provide a stochastic speckle pattern for the purpose of collecting three-dimensional photogrammetry data during the test. Sixty-four channels of data were collected at 10,000 samples per second using the onboard DAS. The DAS system was located behind the pilot and co-pilot seats in the location where luggage would normally be stored, or passenger seats would be added. Thus, the DAS system provided ballast to the airframe. Additional lead weight was added over the wing to simulate fuel weight. The lead, along with the main swing hardware accounted for approximately 100 lb. of weight over each wing, which simulated fuel tanks above 75% full. Finally, onboard and external high-speed video coverage was obtained from internal and exterior cameras.



Figure 1. Pre-test photograph of C-172 crash Test 1.

The LandIR facility is used to conduct full-scale crash tests of aircraft using either a single (which introduces a pitch rate) or parallel (which removes the pitch rate) swing cabling system.

For Test 1, a single set of swing cables was connected to the west end of the LandIR facility and was attached to hard points on the aircraft. Pullback cables were connected on one end to a movable overhead bridge located on the east side of the LandIR facility and on the other end to the test article. As the pullback cables are retracted using the bridge winch system, the aircraft is lifted into the air to a pre-determined drop height. Following a countdown, a pyrotechnic system severs the pullback cables, causing the test article to swing along a pendulum-like flight path from east to west onto a pre-determined impact location on the ground. Just prior to impact, the swing cables are pyrotechnically separated allowing the aircraft to impact the surface in a free (unconstrained) condition. Various combinations of swing cable length, impact location, drop height, impact surface conditions (rigid, soil or water) along with a test article's angle of attack can be prescribed, creating a wide variety of impact conditions.

Test 1 essentially represented a "hard" landing. Initially the nose gear tire impacted the concrete, followed closely by impact of the main gear tires. The main landing gear spread outward, as the nose gear stroked vertically. The only fuselage contact with the impact surface was a slight impact of the rearmost portion of the lower tail. After this impact, the airframe rebounded upward. At approximately 0.5-s following initial impact, the aircraft hit a net that was setup to limit forward displacement of the aircraft. Some damage to the nose cone and nose gear support structure was evident; however, following the test, the aircraft was rolled back to the storage facility using the nose and main landing gear tires, which were still inflated. A post-test photograph of the test article is shown in Figure 2. Evidence of damage to the wing based on contact with the net can also be observed. Thus, it became apparent following the test that capturing the behavior of the nose and main landing gear was essential to achieving accurate prediction of the airframe dynamic response. Consequently, landing gear component tests have been conducted and test results are currently being evaluated.



Figure 2. Post-test photograph.

LS-DYNA Finite Element Model Development

Development of the LS-DYNA model was complicated by the fact that no prior geometry or static loads models of the C-172 airframe existed and no engineering drawings were available. Consequently, the original model was generated using a three-dimensional laser scan of the test article. The resulting point cloud was converted to a geometry model, which was discretized into a finite element model.

The model representing the Test 1 configuration is shown in Figure 3. This model contains 135,637 nodes; 252 beam elements; 139,973 shell elements; 908 solid elements; 1 discrete beam; 44 parts; 8 Constrained Nodal Rigid Bodies (CNRBs); 16 different materials; 1,524 concentrated masses; 1 card defining gravity; and 1 rigid wall. All nodes forming the aircraft model were assigned the same initial velocity conditions as measured for the test (722.4-in/s forward velocity and 276-in/s vertical velocity). In addition, a pitch angular velocity of 16.5-degrees/second was assigned about the Center-of-Gravity (CG) of the model representing the measured condition. The aircraft was also pitched by 1.5° (nose up) to match the orientation of the test article at impact. The concrete impact surface, which is not depicted in Figure 3, was modeled as a horizontal rigid wall, located just below the model. Most of the shell elements used in the model were assigned a Belytschko-Tsay (Type 2) formulation; however, the shell elements forming the main gear leaf springs were assigned a fully integrated formulation (Type 16). A nominal shell element edge length of 1-in. was used. In addition, four ELTs were included in the model and they were represented as rigid boxes made of solid elements. Two ELTs were located on the floor behind the pilot and co-pilot seats and two were mounted to the left and right sidewalls of the tail, as shown in the cutaway views of the model in Figures 4(a) and (b). Other ballast including the wing fuel, engine, nose cone, propeller, DAS box, two seats, and the two ATD occupants were simulated as concentrated masses.

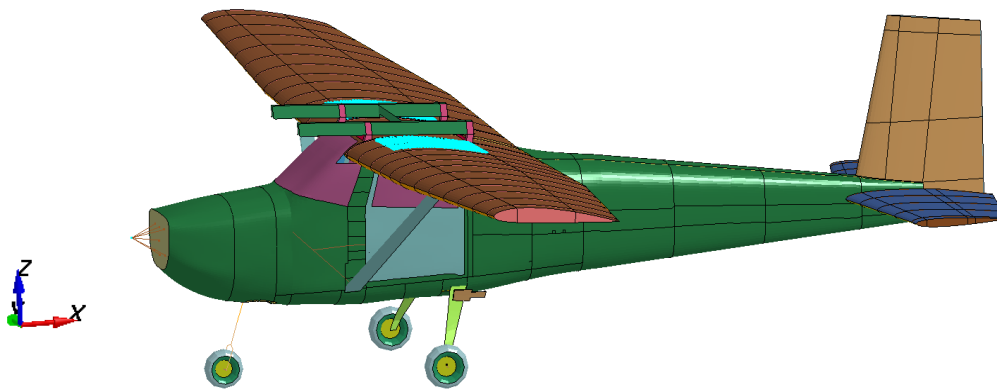

Figure 3. LS-DYNA model representing the Test 1 configuration.

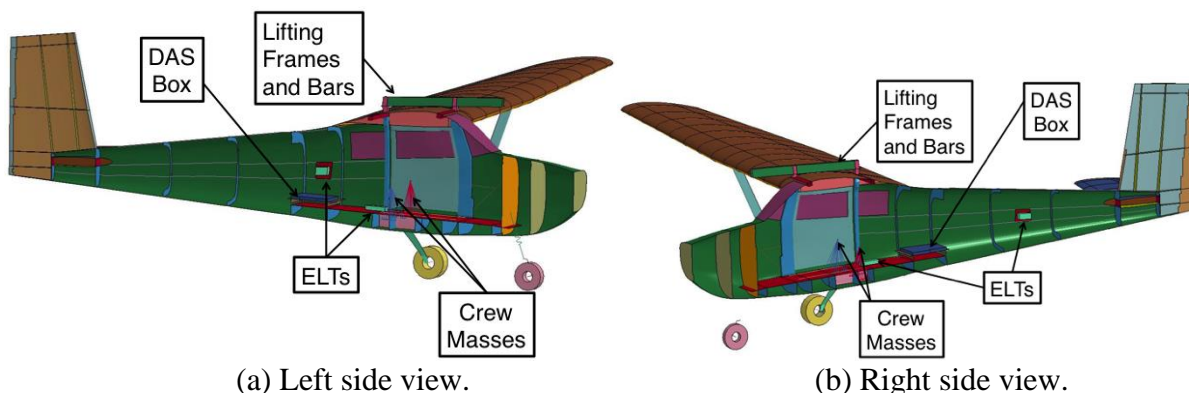

Figure 4. Cutaway views of the model.

As stated in Reference 8, the landing gear of the Cessna 172 is a tricycle type with a steerable nose wheel, and two main wheels. Shock absorption is provided by the spring-steel main landing gear struts and the nose gear oleo-pneumatic shock strut. A schematic drawing of the nose gear is shown in Figure 5(a) along with a depiction of the model of the nose gear in Figure 5(b). In

the model, the nose gear wheel was modeled as a collection of several parts including the tire, axle, rim, hub, and yoke. The oleo-pneumatic shock strut was represented as a telescoping beam that was attached on one end to the wheel yoke and on the other to a CNRB that was attached to the firewall at several locations. The telescoping beam was assigned estimated load-displacement properties for the given impact velocity condition. The material property assigned to the beam was *MAT_GENERAL_SPRING_DISCRETE_BEAM. A depiction of the main gear model is shown in Figure 6. The large structure that connects the wheel assembly to the subfloor, called the main gear leaf spring or strut, is represented using Type 16 shell elements that are 0.7-in. thick. The main gear leaf springs are curved slightly to match the shape of the actual main gear structure, and steel plates were added near the top of the leaf springs for use in lifting the aircraft during the test. Finally, the leaf springs were assigned material properties representing spring steel using the *MAT_PLASTIC_KINEMATIC card in LS-DYNA.

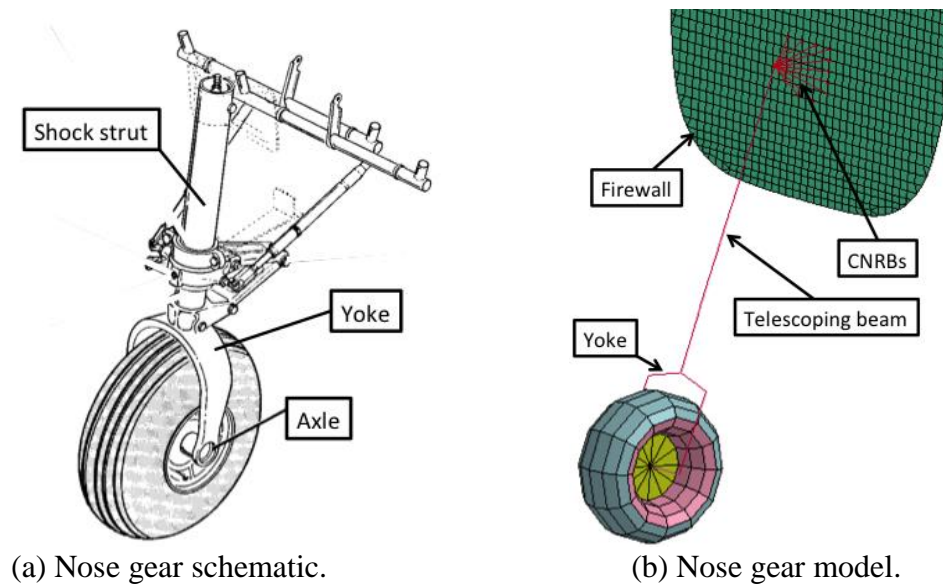

Figure 5. Cessna 172 nose gear.

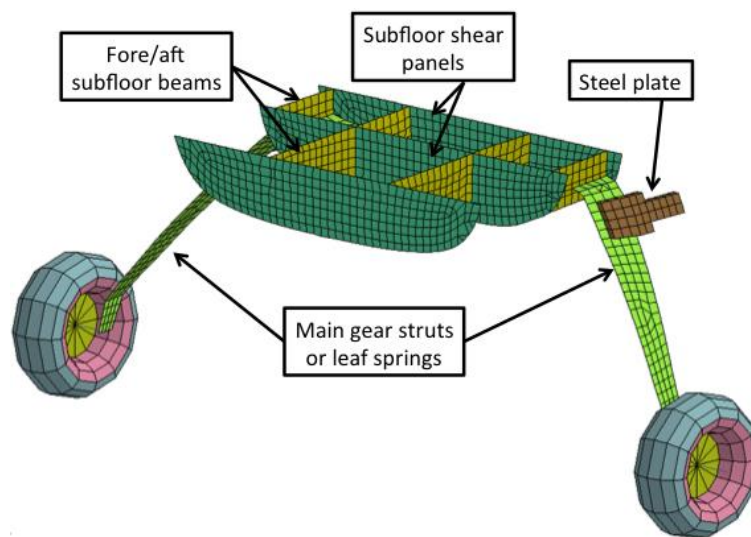

Figure 6. Main gear model.

The model was executed for 0.325-s on a Linux workstation computer with 8 processors, running LS-DYNA V971 R712 SMP double precision, and required 32 hours and 30 minutes clock time to reach normal termination. Nodal output requests for the simulation included acceleration- and velocity-time histories at locations matching accelerometers mounted in the test article.

Test-Analysis Comparisons

Test-analysis comparisons are presented in three categories: model and test article inertial properties, time sequence of events, and time-history plots of vertical acceleration and velocity. For the acceleration time histories, both the test data and analytical predictions were filtered using a Society of Automotive Engineers (SAE) Channel Filter Class (CFC) 20-Hz low-pass filter [9]. In addition, the CG vertical velocity is plotted versus two predicted responses that are located near the CG. For this plot, the vertical CG response was determined based on photogrammetric analysis. Note that the primary loading during the first 0.35-s of the impact event was in the vertical direction. During this time period, forward accelerations were extremely low, until the aircraft impacted the catch net at approximately 0.5-s. As a result, the simulation is focused on predicting vertical responses only.

Inertial Properties

As an initial check of model fidelity, a comparison of inertial properties was made and the results are shown in Table 1. Note that the CG subscripts refer to the coordinate axes shown in Figure 3. It should also be noted that the x-direction CG values are measured from the firewall, the y-direction CG values are measured from the centerline of the aircraft, and the z-direction CG values are measured from the ground.

Table 1. Test-Analysis Comparison of Inertial Properties.

Parameter	Model	Test	Difference	% Difference
Total weight, lb.	1,998.1	2,000.0	1.9	0.1
CG _x , in.	43.3	44.5	1.2	2.7
CG _y , in.	-0.05	0.00	0.05	-
CG _z , in.	51.1	46.3	-4.8	10.4

As indicated in Table 1, the model weight was within 2-lb of the 2,000-lb test article weight, and the CG locations were within 2-5 inches. These results are an indication that the model represented the inertial properties of the test article reasonably well.

Time Sequence of Events

A comparison of the time sequence of events is shown in Figure 7. This figure highlights four major events occurring during the time sequence including: initial nose gear impact, the time of maximum main gear spread, time of tail impact, and time at which rebound occurs, i.e. the tires are no longer in contact with the impact surface. For the test, the event timing was determined based on photogrammetric analysis. A side view of the model is shown at the time of each event. Photographs taken from a side view camera are shown for the test for the first three events; however, by the time of rebound, the aircraft had traveled outside the field of view of this camera. Consequently, an image was used from another camera for the fourth event. The model predicts the time of maximum main gear spread within 0.005-s. However, the predicted time of tail impact is 0.155-s compared with 0.125-s for the test. Also, the time of rebound differs

between the test and the model by 0.044-s. It should be noted that the time of tail impact is confirmed based on an acceleration response obtained from that location. However, the time of rebound for the test is difficult to determine precisely from the camera views. Based on the results shown in Figure 7, the model accurately captured the kinematics of the test.









Event	Model	Test
Initial Impact		
	T= 0.0-s	T= 0.0-s
Time of max main gear spread		
	T= 0.085-s	T= 0.09-s
Time of tail impact		
	T= 0.155-s	T= 0.125-s
Time of initial rebound		
	T= 0.322-s	T= 0.366-s

Figure 7. Time sequence of events comparison.

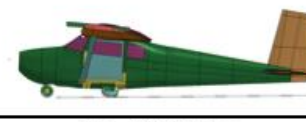
Time-History Comparisons

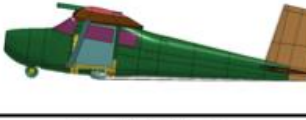
Filtered vertical acceleration time-history comparisons are shown in Figures 8-13 matching various accelerometer locations within the test article. As an indication of the level of test-analysis comparisons, average accelerations were determined for both the test and predicted responses based on actual pulse durations for each response. The value of average acceleration is shown in the curve label of each plot. In addition, integrated vertical velocity responses are shown for each location. Finally, test-analysis velocity responses of the four ELTs that were mounted in the aircraft are shown in Figures 14-15. Table 2 summarizes the test-analysis data including average acceleration, pulse duration, and change in velocity (ΔV).

Several observations can be made by examining the comparison plots shown in Figures 8-15. First, even though the test and analysis data were filtered using an SAE CFC20 filter, the acceleration responses still contain a high level of oscillations, making it difficult to extract an underlying acceleration pulse. Yet, the data in these plots were analyzed, as shown in Table 2. Several checks were performed to ensure that the filtering process did not distort the data in any way. Average acceleration values for the test were generally low in magnitude, ranging from 3.57-g at the pilot floor location to 4.98-g in the tail. The predicted average accelerations showed excellent agreement with the test data, also indicating a range of 3.67-g for the pilot floor location and 4.96-g at the tail. For all of the parameters that were compared in Table 2, the maximum percentage difference was 9.9%. Comparisons of vertical velocity responses were

particularly close, with the model capturing the significant change in slope of the vertical velocity response of the tail, as shown in Figure 13. Likewise, comparisons of the floor- and sidewall-mounted ELT vertical velocity responses were in close agreement. It should be noted that since the pitch attitude of the aircraft at impact was small (less than 2°), the ELT predictions were generated using the global coordinate system. For Tests 2 and 3, local coordinate systems are required.

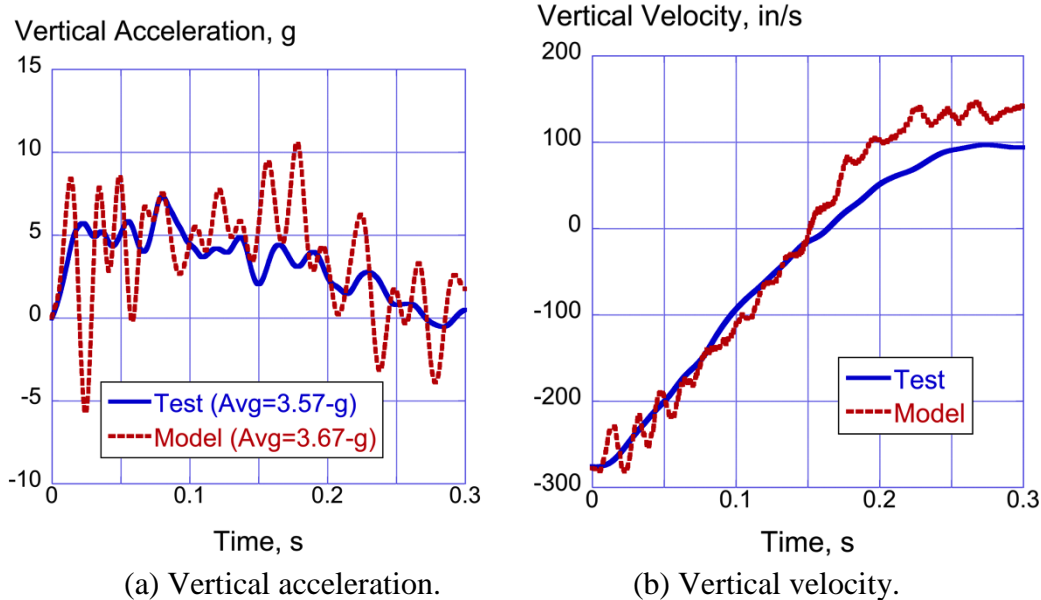

Figure 8. Test-analysis comparison of acceleration and velocity responses for the pilot floor.

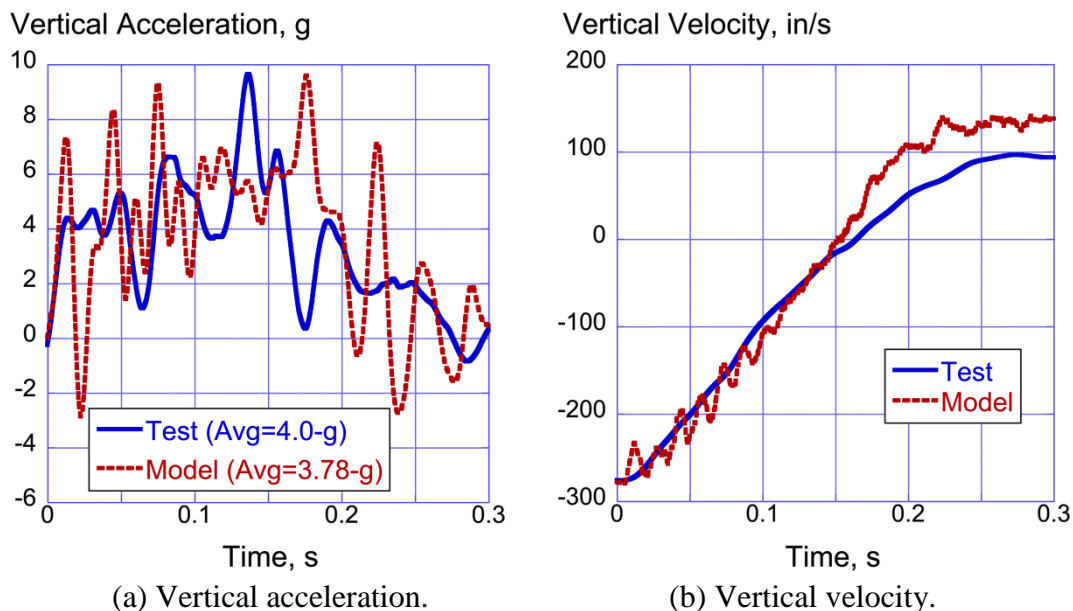

Figure 9. Test-analysis comparison of acceleration and velocity responses for the copilot floor.

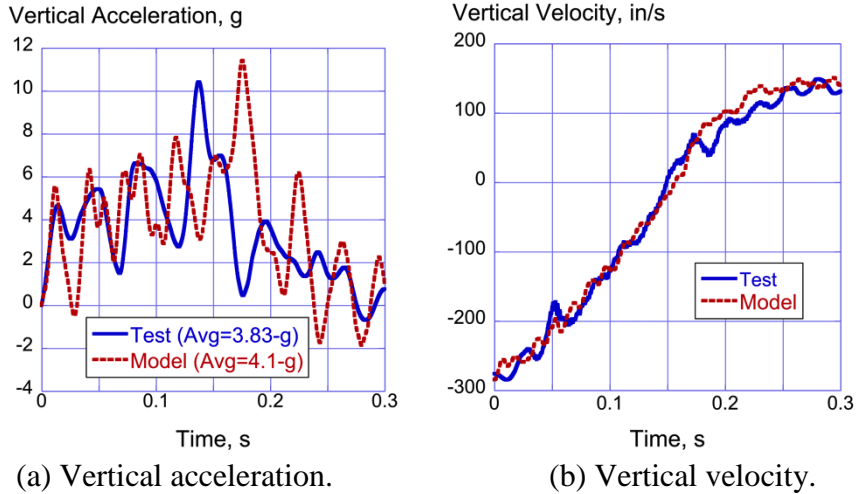

Figure 10. Comparisons of acceleration and velocity responses for the left doorframe.

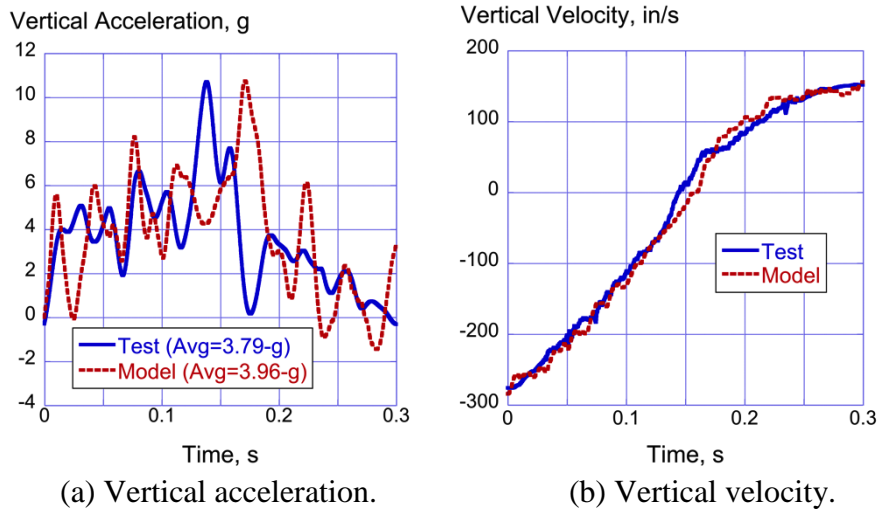

Figure 11. Comparisons of acceleration and velocity responses for the right doorframe.

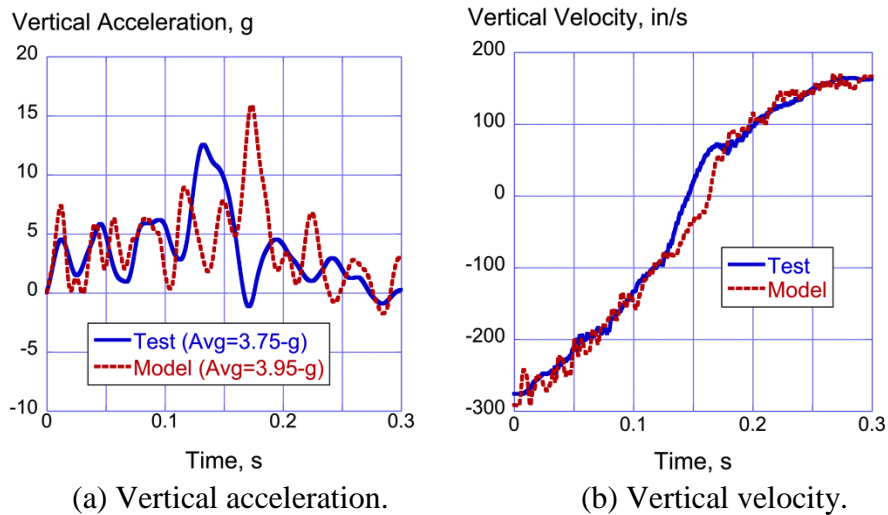

Figure 12. Comparisons of acceleration and velocity responses for the DAS box/floor.

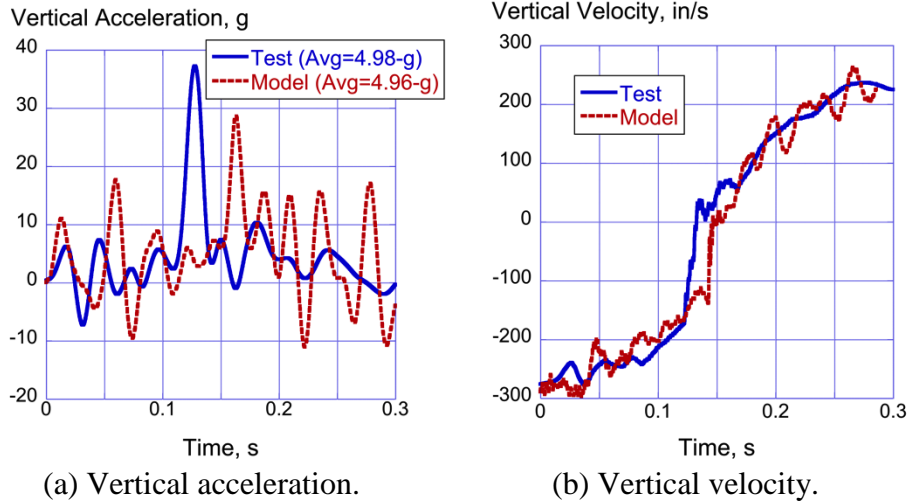

Figure 13. Comparisons of acceleration and velocity responses for the tail.

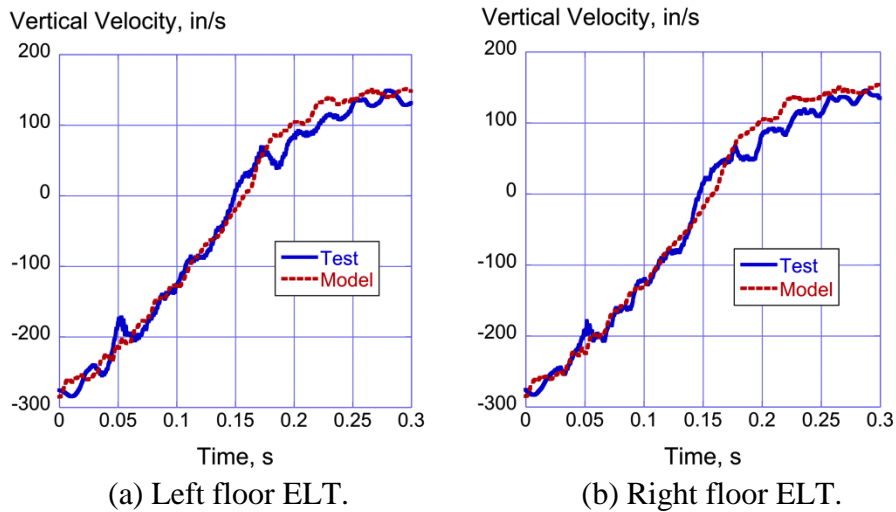

Figure 14. Test-analysis vertical velocity responses of floor mounted ELTs.

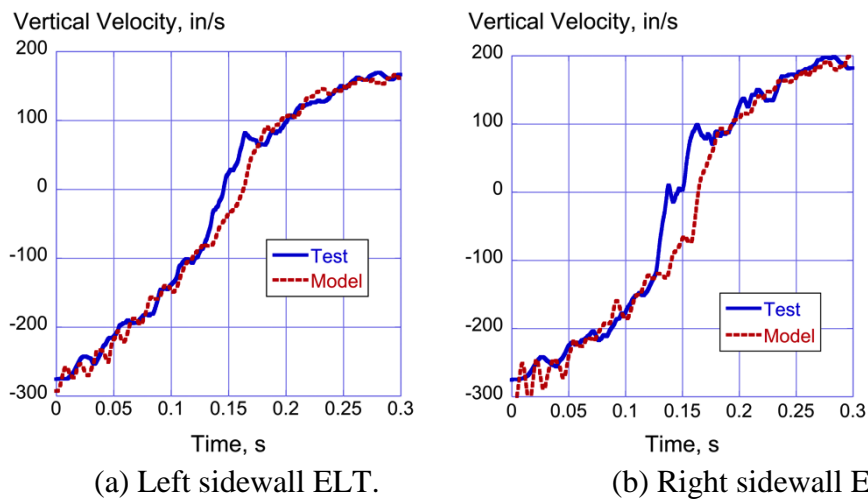

Figure 15. Test-analysis vertical velocity responses of sidewall mounted ELTs.

Table 2. Summary of test-analysis comparisons.

Location	Parameter	Test	Model	% Difference
Pilot Floor	Avg. Vt. Accel, g	3.57	3.67	-2.8
	Pulse duration, s	0.27	0.29	-7.4
	delta-V, in/s	376.0	413.2	-9.9
Co-pilot floor	Avg. Vt. Accel, g	4.0	3.78	5.5
	Pulse duration, s	0.27	2.8	-3.7
	delta-V, in/s	376.0	412.2	-9.6
Lt. Doorframe	Avg. Vt. Accel., g	3.83	4.1	-7.0
	Pulse duration, s	0.2725	0.272	0.2
	delta-V, in/s	402.4	426.4	-6.0
Rt. Doorframe	Avg. Vt. Accel., g	3.79	3.96	-4.5
	Pulse duration, s	0.281	0.279	0.7
	delta-V, in/s	424.6	418.5	1.4
DAS Box	Avg. Vt. Accel., g	3.75	3.95	-5.3
	Pulse duration, s	0.282	0.293	-3.9
	delta-V, in/s	439.8	440.0	-0.05
Tail	Avg. Vt. Accel., g	4.98	4.96	0.4
	Pulse duration, s	0.266	0.269	-1.1
	delta-V, in/s	541.3	533.2	1.5
Lt. floor ELT	delta-V, in/s	424.6	423.2	0.3
Rt. floor ELT	delta-V, in/s	419.0	423.0	-1.0
Lt. sidewall ELT	delta-V, in/s	445.4	439.9	1.2
Rt. sidewall ELT	delta-V, in/s	474.6	476.0	-0.3

One of the test-analysis response metrics compared and included in this paper was the change in velocity (delta-V). The delta-V metric represents the total change in velocity, from initial velocity to maximum rebound velocity. This metric is important because the built-in threshold electronics (g-switches) in most ELTs are designed to activate in accordance with a delta-V specification [10]. All delta-V values were well predicted by the model, as indicated in Table 2.

Finally, a plot of measured vertical velocity of the CG is shown in Figure 16, along with predicted velocity responses from two nearby locations, the DAS box and the rear center ceiling beam. These channels were selected since no direct nodal output was obtained from the CG in the simulation. The experimental data were determined based on photogrammetry and the response contains some “noise” or “chattering” due to image triangulation and focusing. However, the agreement between the test response and the two selected channels is excellent. Both the test and predicted responses cross zero velocity at or near 0.15-s and both achieve maximum rebound of approximately 125- to 150-in/s by 0.25- to 0.3-s.

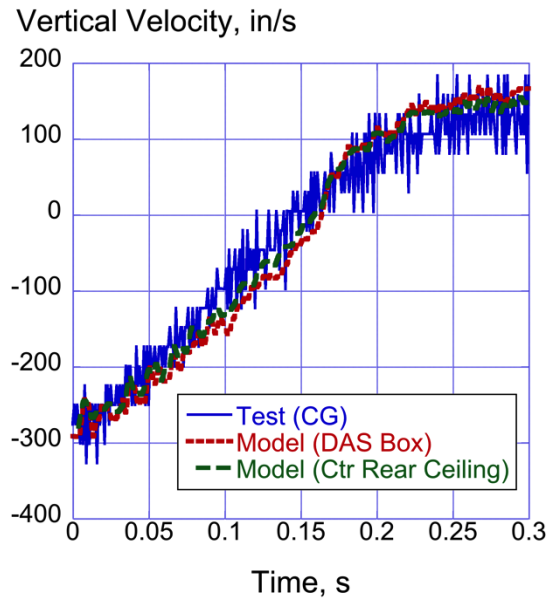

Figure 16. Test velocity response of the CG, as measured by photogrammetry, compared with the predicted velocity responses of the DAS box and the rear center ceiling support beam.

Conclusions

A full-scale crash test of a Cessna 172 General Aviation aircraft was conducted at NASA Langley Research Center in the summer of 2015. The purpose of the crash test was to evaluate the performance of Emergency Locator Transmitters (ELTs) and to generate impact test data for model validation. A full-scale finite element model of the test article was developed and LS-DYNA simulations were executed to replicate the impact test conditions of 722.4-in/s forward velocity and 276-in/s vertical velocity with a 1.5° pitch (nose up) attitude. The impact surface was concrete. During the test, the nose gear tire impacted the concrete, followed closely by impact of the main gear tires. The main landing gear spread outward, as the nose gear stroked vertically. The only fuselage contact with the impact surface was a slight impact of the rearmost portion of the lower tail. Thus, it became apparent following the test that capturing the behavior of the nose and main landing gear was essential to achieving accurate prediction of the airframe dynamic response.

Findings are listed, as follows:

- (1) Total weight and Center-of-Gravity (CG) locations of the test article and the model were a reasonable match indicating good prediction of the inertial properties of the test article.
- (2) The model accurately predicted the kinematic response of the test article including initial nose gear impact, the time of maximum main gear spread, time of tail impact, and time at which rebound occurs.
- (3) Average accelerations were calculated for both test and predicted responses. Vertical accelerations were extremely low with average values for the test ranging from 3.57- to 4.98-g. In comparison, predicted values ranged from 3.67- to 4.96-g.
- (4) Test-analysis comparisons of vertical velocity responses were particularly close, with the model capturing the significant change in slope of the vertical velocity response of the tail quite well.

- (5) Three different parameters were tabulated to assess the level of test-analysis comparisons including average acceleration, pulse duration, and delta-V. The highest percentage difference between any measured and predicted parameter was 9.9%.

References

1. Annett M.A., Littell J. D., Stimson C. M., Jackson K.E., and Mason B.H., "Full-Scale Crash Tests and Analyses of Three High-Wing Single Engine Aircraft," Aerospace Structural Impact Dynamics International Conference, Seville, Spain, November 17-19, 2015.
2. Littell J. D., "Crash Tests of Three Cessna 172 Aircraft at NASA Langley Research Center's Landing and Impact Research Facility," NASA/TM-2015-218987, November 2015.
3. Fasanella E. L., and Jackson K.E., "Crash Testing and Simulation of a Cessna 172 Aircraft: Pitch Up Impact onto Soft Soil," Proceedings of the 14th International LS-DYNA Users Conference, Dearborn, MI, June 13-14, 2016.
4. Hallquist J. Q., "LS-DYNA Keyword User's Manual," Volume I, Version 971, Livermore Software Technology Company, Livermore, CA, August 2006.
5. Hallquist J. Q., "LS-DYNA Keyword User's Manual," Volume II Material Models, Version 971, Livermore Software Technology Company, Livermore, CA, August 2006.
6. Thomson, Robert G., and Robert C. Goetz. "NASA/FAA General Aviation Crash Program – A Status Report." *Journal of Aircraft*, Vol. 17, No. 8, pp. 584-590, August 1980.
7. Vaughan, V.L. and Robert J. Hayduk, "Crash Tests of Four Identical High-Wing Single-Engine Airplanes," NASA TP-1699, August 1980.
8. Cessna Skyhawk Information Manual, 1980 Model 172N, Cessna Aircraft Company, Wichita, Kansas, 1991.
9. Society of Automotive Engineering (SAE) J211-1 Instrumentation for Impact Test – Part 1-Electronic Instrumentation, Revision March 1995, SAE International, 400 Commonwealth Drive, Warrendale, PA.
10. RTCA SC-229/EUROCAE WG-98, "Aircraft Emergency Locator Transmitters (ELTs)," May 1, 2014, Annapolis, MD.