

Benchmark of LS-DYNA[®] for Off-shore Applications according to DNV Recommended Practice C208

Marcus Lilja

DYNAmore Nordic AB, Linköping, Sweden

Abstract

The use of non-linear FEA is growing in the offshore industry. Det Norske Veritas AS (DNV), one of the world's largest ship and offshore classification societies to the maritime industry, has developed a Recommended Practice (DNV-RP-C208) on the usage of non-linear implicit finite element simulations in offshore applications. DNV-RP-C208 creates a de facto standard for structural load capacity analysis of off-shore structures. The Recommended Practice in combination with handbook formulas and empirical data create a de facto standard that will be used for investigations, studies and dimensioning off-shore structures for years to come. The Recommended Practice contains several benchmark problems with references solutions that can be used to verify a finite element software and the modeling methodology.

This paper presents results from LS-DYNA for a selection of these benchmark problems, ranging from beam bending problems with elasto-plastic behavior to instability and collapse analysis. All benchmark problems are solved using the implicit non-linear solver. Development of new features in LS-DYNA and LS-PrePost[®] were necessary in order to complete the task. This paper presents results from the benchmarks, solution techniques, and the newly developed features.

Introduction

Det Norske Veritas AS (DNV) is one of the world's largest ship and offshore classification societies for the maritime industry. DNV standards, requirements and recommendations are widely used in the offshore industry. The DNV-RP-C208[1] is a new document intended to give guidance on how to use non-linear FEA to establish structural resistance. Simulations performed according to DNV-RP-C208[1] reassures that the characteristic resistance obtained for the structure fulfils the requirements to ultimate strength according to DNV standards. Characteristic resistance is, in this case, defined as: *"The characteristic resistance should represent a value which will imply that there is less than 5% probability that the resistance is less than this value"*. The document is valid for marine structures made of structural steel that fulfils the requirements in DNV-OS-C101[2] for structural steel with a yield strength up to 500 MPa. The document deals with Ultimate-, Accidental- and Fatigue Limit States and is only to be used when the case studied is not covered by any other standard or code. Failure modes included in this Recommended Practice are Tensile failure, Failure from repeated loading (LCF only), Accumulated plastic strain, Buckling and Repeated buckling. DNV-RP-C208 includes several validated example problems solved using another commercial FE-code. These validated example problems have been used to benchmark the LS-DYNA implicit solver for offshore applications according to DNV-RP-C208[1]. The results from this benchmark for a selection of these example problems are presented in this paper.

DNV-RP-C208 is available for download at: http://www.dnv.com/resources/rules_standards

Objective

The purpose of this work is to create a white paper with the DNV-RP-C208[1] example problems solved using the LS-DYNA implicit solver. The paper will serve as a documented validation of the implicit LS-DYNA solver for offshore applications according to DNV-RP-C208[1]. The intension is to distribute this document to customers that are interested in using LS-DYNA for such applications. This white paper will be available in the end of 2014.

Feature development

Maximum principal plastic strain is frequently used as a strain measure in DNV-RP-C208. This strain measure was not available in LS-DYNA when this work started but had to be implemented. Today (from R7.1.0) it is available by request for *MAT_024. The output of this strain measure is activated by setting STRFLG=10 on *DATABASE_EXTENT_BINARY, see the LS-DYNA keyword manual. Also, enhanced sorting of higher order shell elements had to be included (available in R7.0.0) and improvements in the arc-length solver. The latter will be available in the version to follow R7.1.0.

Implicit settings

In order to run these non-linear simulations implicit control cards must be set-up in LS-DYNA. This section is intended to show recommended implicit settings for the work presented in this paper. Control card parameters within parenthesis are used for arc-length solutions only.

*CONTROL_IMPLICIT_GENERAL

Recommended settings are shown in Figure 1. Set IMFLAG=1 to activate the implicit solver. For arc-length solutions it is recommended to include geometric stiffness effects by setting IGS=1, otherwise default.

```
*CONTROL_IMPLICIT_GENERAL
$# imflag      dt0      imform      nsbs      igs      cnstn      form      zero_v
      1  0.010000      2          1      2(1)      0          0          1
```

Figure 1. *CONTROL_IMPLICIT_GENERAL card with recommended settings.

*CONTROL_IMPLICIT_AUTO

Recommended settings are shown in Figure 2. Set IAUTO=1 to activate automatic time stepping.

```
*CONTROL_IMPLICIT_AUTO
$#  iauto      iteopt      itewin      dtmin      dtmax      dtexp
      1
```

Figure 2. *CONTROL_IMPLICIT_AUTO card with recommended settings.

*CONTROL_IMPLICIT_SOLUTION

Recommended settings are shown in Figure 3. Non-linear solver(nsolvr) 12 is used for solving these problems. When arc-length solutions are requested non-linear solver 12 and arc-length method(arcmt) 3 is used. It is also recommended that the number of the absolute tolerance value(abstol) is decreased from 1.0e-10 to 1.0e-20 in order to prevent premature convergence.

```
*CONTROL_IMPLICIT_SOLUTION
$# nsolvr      ilimit      maxref      dctol      ectol      rctol      lstol      abstol
      12
$#  dnorm      diverg      istif      nlprint      nlnorm      d3itctl      cpchk
      2
$#  arcctl      arcdir      arclen      arcmt      arcmt      arcmt      arcmt
      (3)
```

Figure 3. *CONTROL_IMPLICIT_SOLUTION card with recommended setting.

Examples

Example 1: Strain limits for tensile failure due to gross yielding of plane plates, T-section cantilever beam

Dimensions are according to Figure 4. Material grade S355 is used, true stress strain material data according to [1] are used in a *MAT_PIECEWISE-LINEAR_PLASTICITY-model. The loads are applied at a node that coincides with the neutral axis of the beam at the beam cross section. This node is connected to the beam cross section by a nodal rigid body. The model consists of higher order shell elements (ELFORM=23).

Load case:

$$N_x = 489 \text{ kN}$$

$$P_y = -0.15 \cdot N_x$$

$$M_z = -0.45 \cdot N_x$$

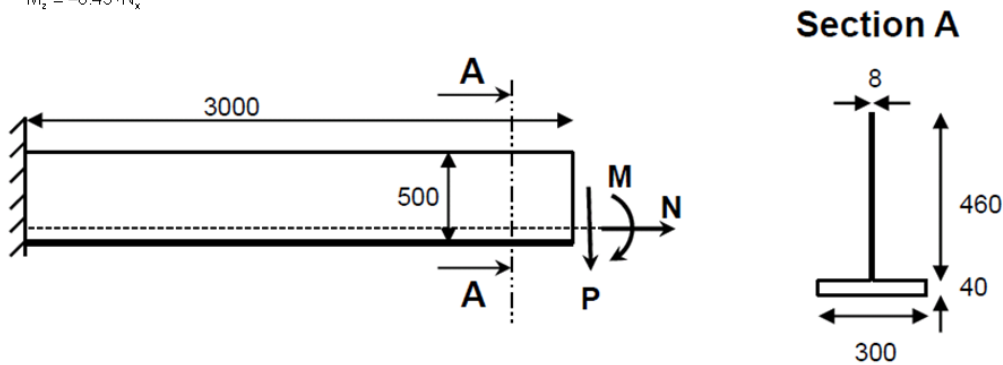

Figure 4. Dimensions and loading.

According to the criterion in [1] the strain should be calculated as linearized maximum principal plastic strain along a likely failure line and it should be checked against the limit for the critical strain. For the gross yielding, the likely failure line is chosen as the 3rd element row from the clamped end, see Figure 5. The strain limit is a critical gross yield strain of 0.04[1] for this example. For the chosen failure line the maximum principal plastic strain is linearized using the method of least squares ($\mathbf{A}^T \mathbf{A} \mathbf{x} = \mathbf{A}^T \mathbf{b}$)

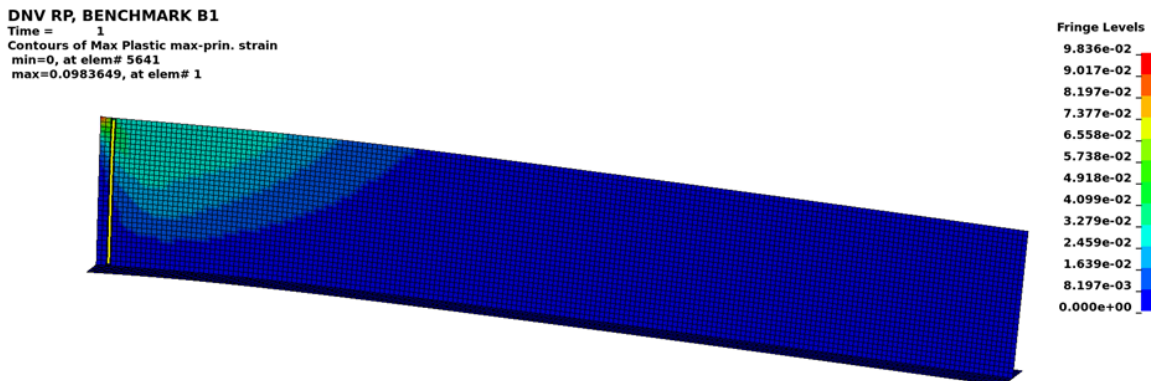

Figure 5. Fringe plot of maximum principal plastic strain, failure line highlighted.

Figure 6 shows maximum principal plastic strain along the failure line. As seen the result from LS-DYNA shows good agreement to the result in [1]. A comparison of results is shown in Table 1.

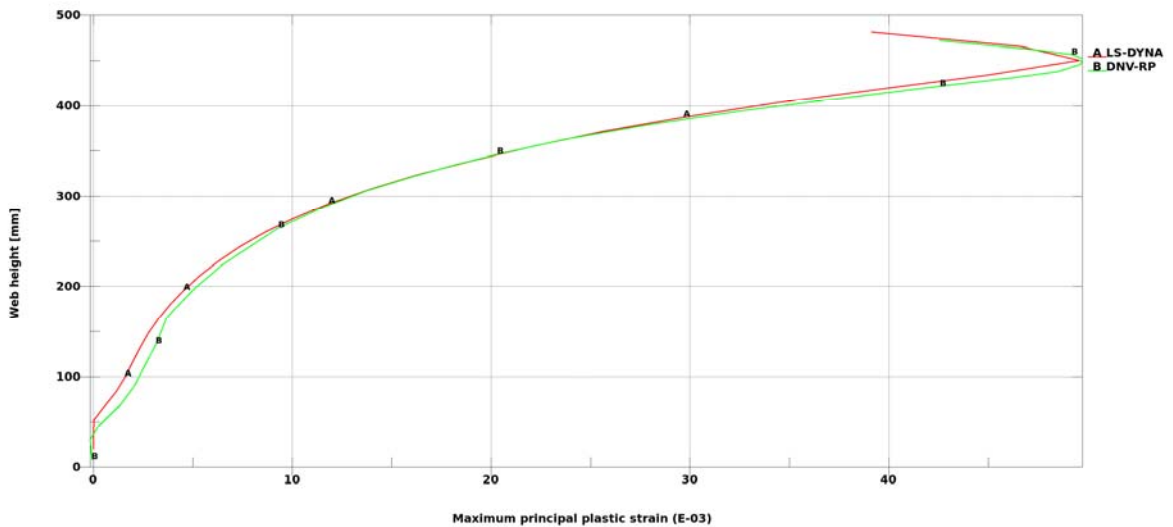

Figure 6. Comparison of maximum principal plastic strain along failure line from LS-DYNA and DNV-RP-C208.

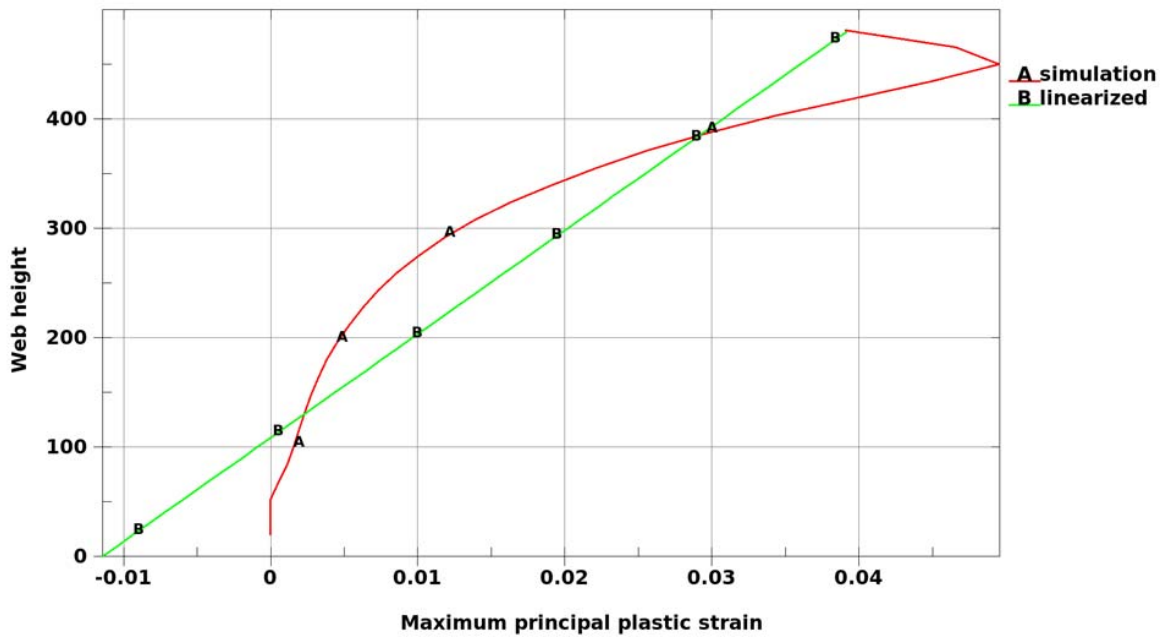

Figure 7. Maximum principal plastic strain and linearized maximum principal plastic strain along failure line.

Table 1. Comparison of results from LS-DYNA and DNV-RP-C208 for example 1

Nx [kN]	Maximum linearized principal plastic strain	
	LS-DYNA	DNV-RP-C208 [1]
489	0.039	0.039

Example 2: Strain limits for tensile failure due to gross yielding of plane plates, T-section cantilever beam with a notch

Dimensions are according to Figure 8. Material grade S355 is used, true stress strain material data according to [1] are used in a *MAT_PIECEWISE-LINEAR_PLASTICITY-model. The loads are applied at a node that coincides with the neutral axis of the beam at the beam cross section. This node is connected to the beam cross section by a nodal rigid body. The model consists of higher order shell elements (ELFORM=23).

Load case:

$$N_x = 310/315 \text{ kN}$$

$$P_y = -0.15 \cdot N_x$$

$$M_z = -0.45 \cdot N_x$$

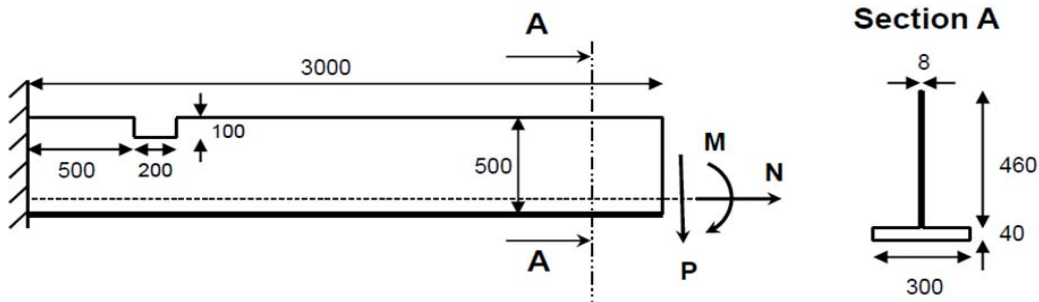

Figure 8. Dimensions and load case, notched beam.

According to the criterion in [1] the strain should be calculated as linearized maximum principal plastic strain along a likely failure line and it should be checked against the limit for the critical strain. For the gross yielding two likely an element row at mid notch and an element row at notch corner is chosen as likely failure lines. The strain limit is a critical gross yield strain of 0.04[1] for this example. Both failure lines must comply with the limit of linearized strain.

The two most likely failure lines, at the corner of the notch (line 1) and at mid notch (line 2), see Figure 9, are used in this example. The results are linearized using the method of least squares ($A^T A x = A^T b$).

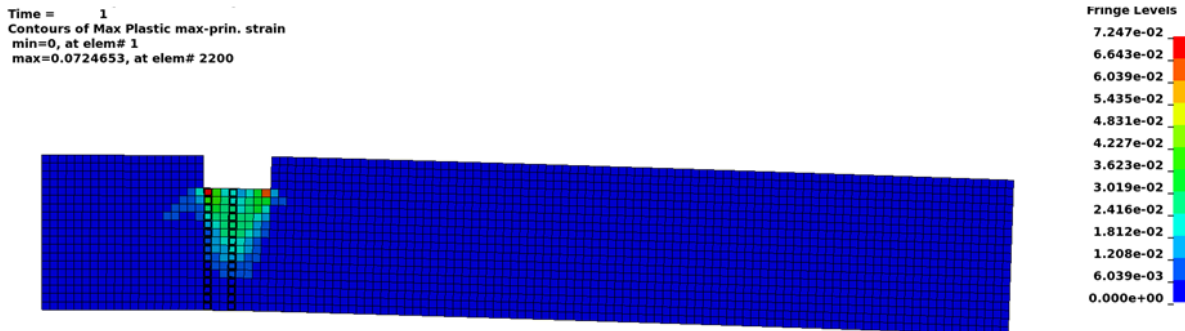

Figure 9. Fringe plot of maximum principal plastic strain, failure lines at notch corner and at mid notch.

Figure 10 and Table 2 show that the LS-DYNA results show good agreement to the results obtained at DNV. The result in Figure 10 is for the 310 kN load case and the location is line 1.

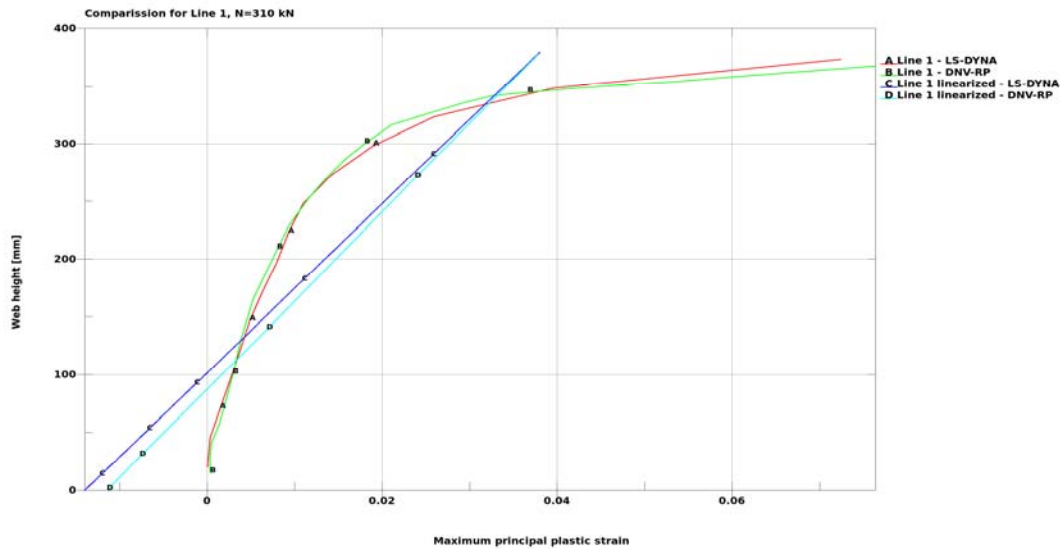

Figure 10. Maximum principal plastic strain along failure line and linearized.

As seen in Table 2 the maximum strain values, at the notch corner, shows very good agreement while the mid notch values differs some more. The difference is still small, maximum difference is only about 0.6%.

Table 2. Comparison of results from LS-DYNA and DNV-RP-C208.

N _x [kN]	Maximum linearized principal plastic strain					
	Line 1 LS-DYNA	Line 2 LS-DYNA	Largest element strain LS-DYNA	Line 1 DNV[1]	Line 2 DNV[1]	Largest element strain DNV[1]
310	0.038	0.036	0.072	0.038	0.030	0.076
315	0.041	0.038	0.077	0.041	0.033	0.081

Example 3: Determination of buckling resistance from non-linear analysis using code defined equivalent tolerances

Figure 11 shows the dimensions and the load case of the frame. Table 3 and Figure 12 describes the material used in this simulation. For more information see [1].

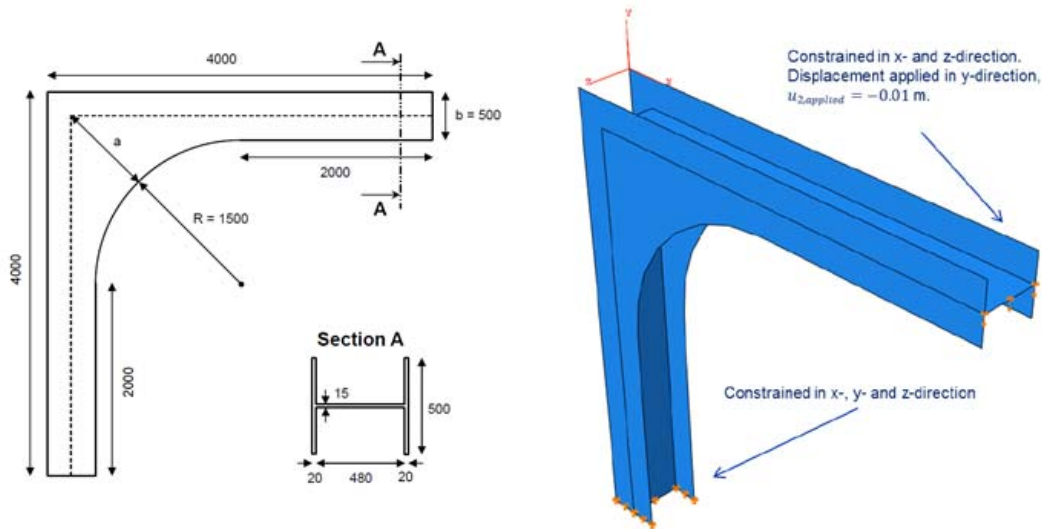

Figure 11. Dimensions and load case description of frame.

Table 3. Material data.

Density	7850 kg/m ³
Young's modulus	210 GPa
Poisson's ratio	0.3
Yield strength	355 MPa

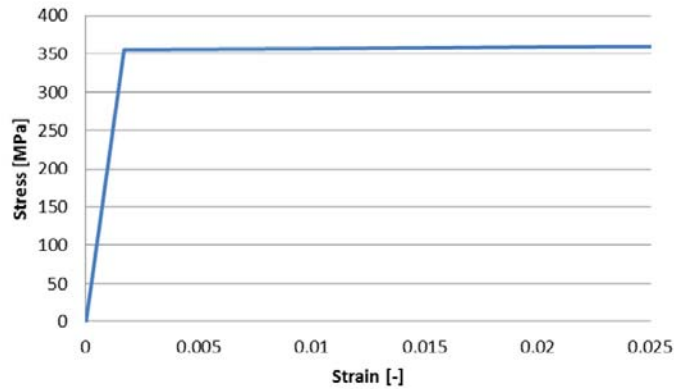

Figure 12. Hardening behaviour of Frame material.

A non-linear buckling analysis using the arc-length method is performed. In this analysis the effects of imperfections, residual stresses and material non-linearity is accounted for. The shape of the governing buckling mode is used, see Figure 13. The governing buckling mode is found from a linear buckling analysis. The first buckling mode in LS-DYNA is found at $k_g = 6.247$ compared to $k_g = 6.243$ [1].

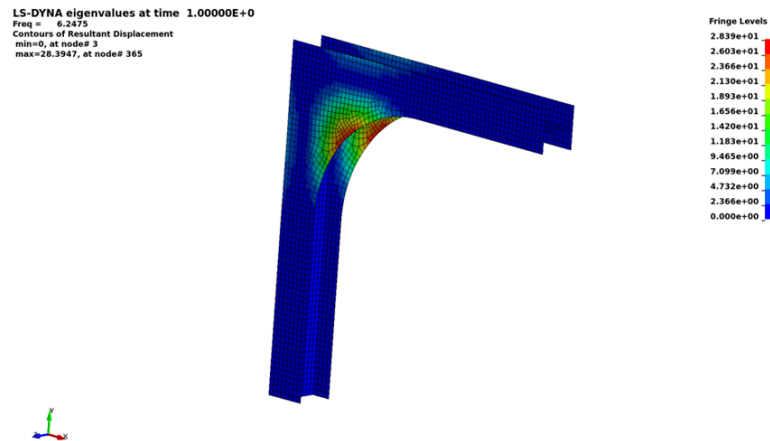

Figure 13. Buckling mode used as basis for imperfections.

The magnitude of the imperfection is determined according to [1], Table 5-7. Two different imperfections are used in this example, these are $\delta_a=0.0195$ m och $\delta_{avg}=0.0122$ m. Imperfections are included by using the *PERTURBATION-keyword.

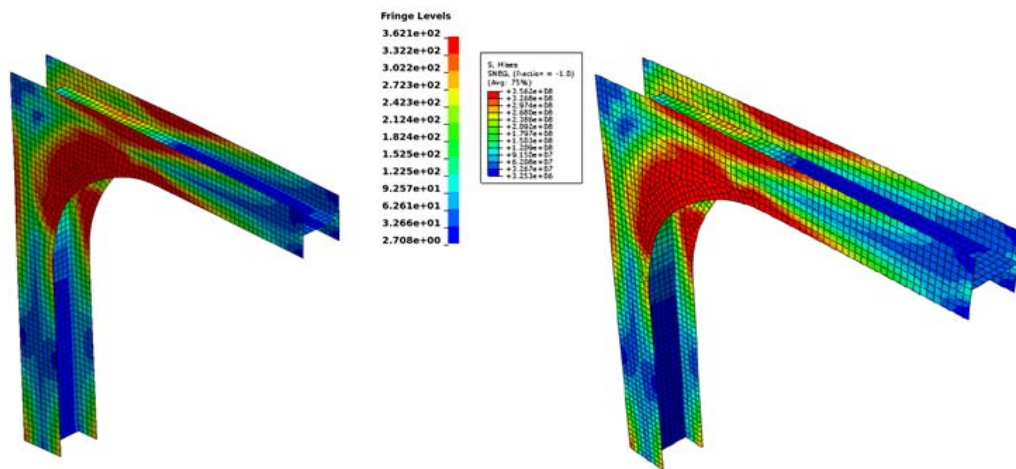

Figure 14. von Mises stress at maximum load according to LS-DYNA(left) and DNV validation(right).

Y-load at the prescribed boundary constraints and the prescribed motion at the same nodes are used to create the curves in Figure 15. As seen, the difference in results is very small. Curve A and B are from DNV-RP-C208[1], curves C and D are from the LS-DYNA simulations.

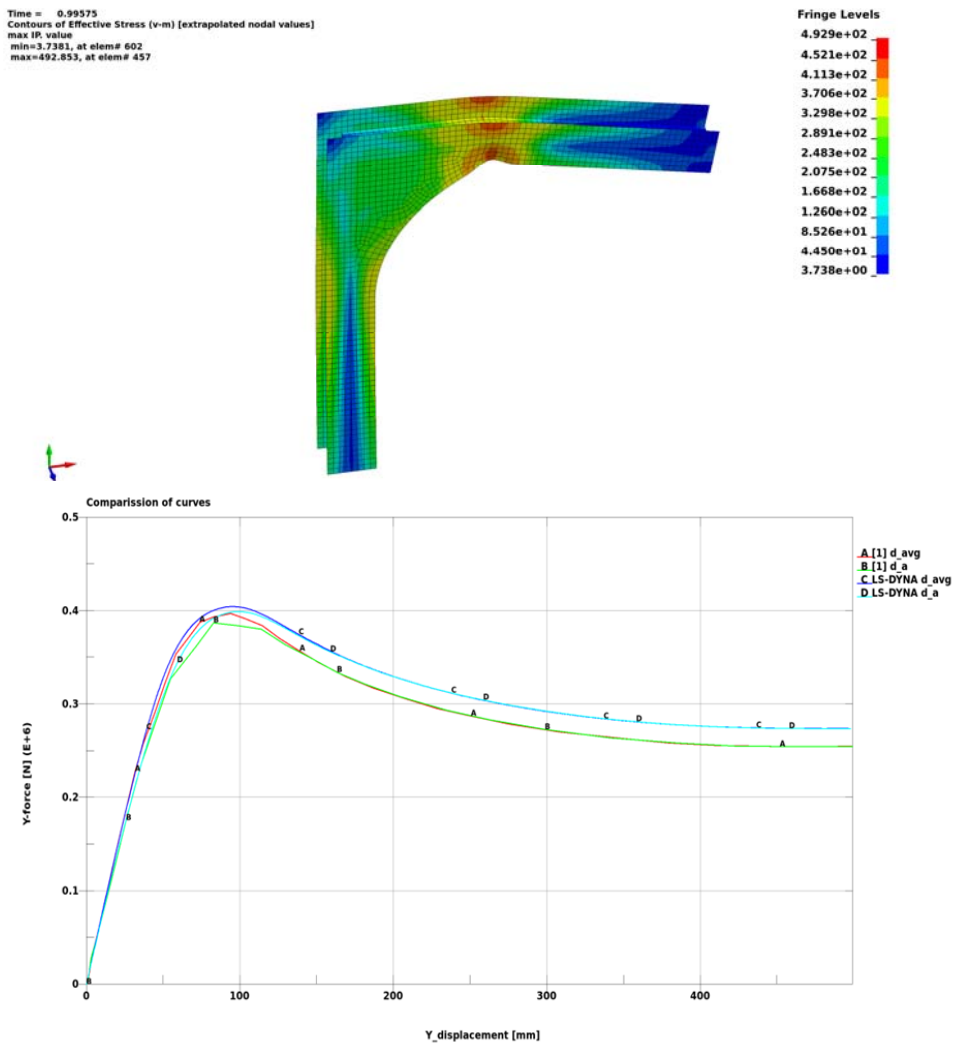

Figure 15. Collapsed frame(top) and load-displacement curve comparison(bottom).

Conclusion

According to above findings the LS-DYNA implicit solver is well suited for offshore applications according to DNV-RP-C208 [1]. Differences in results will be present and may be an effect of difference in convergence tolerances, difference in element technology etc. The results obtained in this study are very similar to the results in DNV-RP-C208[1] both for the tensile failure modes and stability/collapse mode checked.

References

[1] Det Norske Veritas AS, DNV-RP-C208, Determination of Structural Capacity by Non-linear FE analysis Methods, June 2013
 [2] Det Norske Veritas AS, DNV-OS-C101, Design of Offshore Steel Structures, April 2011