

Compression Molding Analysis of Long Fiber Reinforced Plastics using Coupled Method of Beam and 3D Adaptive EFG in LS-DYNA[®]

Shinya Hayashi¹, Hao Chen², Wei Hu²

¹*JSOL Corporation*

2-18-25 Marunouchi, Naka-ku, Nagoya, Aichi, 460-0002, Japan

²*Livermore Software Technology Corporation*

7374 Las Positas Road, Livermore, Ca 94551

1 Abstract

Composite materials like fiber reinforced plastics (FRP) are becoming more widely used in the automotive industry and have been found very effective in reducing vehicle weight. Recently, long carbon fiber reinforced thermoplastics are increasingly being used for lightweight structural parts with high stiffness, strength and energy absorption performance. Compression molding is considered one of the most efficient manufacturing processes to mass produce FRP parts for automotive applications. Compression molding can form long fiber reinforced thermoplastics into complex shapes with relatively low manufacturing cost and short process time. In this paper, a new simulation technology for compression molding of long fiber reinforced plastics implemented in LS-DYNA is presented.

2 Introduction

Automotive manufacturers are considering the use of long fiber reinforced thermoplastics (FRTP) as a material with high strength for satisfying strict crash safety performance as well as weight reduction for fuel efficiency. Compression molding has been proven to be an efficient manufacturing process to form a complicated shape in a short time [1]. However, currently there is a very limited number of high-accuracy simulation technologies available that can predict long fiber orientation, filling timing and other behavior required for compression molding [2][3]. Therefore, in January 2017 a new simulation technology for compression molding of long fiber reinforced plastics was implemented in LS-DYNA.

In the first part of this paper the new simulation technology developed in LS-DYNA is introduced. The main features of this new technology are fibers modelled by beam elements and matrix modelled by tetrahedron solid elements with r-adaptive remeshing function based on an Element-Free-Galerkin (EFG) formulation. Relative motion of beams in the solid elements is simulated by coupling momentum along the normal direction of each beam element. This coupling method transfers load from beam to solid and vice-versa; a so-called strong coupling interaction. Solid elements for the matrix are adequately remeshed with an r-adaptive function which enables large deformations and can generate complex shapes.

The coupling method is similar to that used in LS-DYNA's fluid structure interaction (FSI) capability, in which Eulerian solid elements form the matrix [4]. FSI has good simulation capabilities to predict test results well but generally requires large calculation time because a large number of Eulerian solid elements are required to span the whole model's working space. On the other hand this new simulation technology using r-adaptive remeshing requires solid elements only in the shape of the matrix material. Therefore this new simulation technology can complete compression molding simulation in more practicable calculation time than FSI.

In the second part of this paper an investigation of how to define macroscopic viscosity during compression molding of FRTP is presented. This new simulation technology has the capability for beam elements to slide along the beam axial direction with some resistive force from the solid elements. Our investigations found that macroscopic viscosity during compression molding is controlled by both viscosity of the matrix and the resistive forces against fibers sliding axially in the matrix.

In the final part of this paper compression molding simulation for stampable sheet made of FRTP is presented using a complex shaped punch with one cross-rib geometry. The simulation results show good agreement to experiment and provide valuable information regarding fiber orientation, fiber axial forces, filling timing, weld line locations, maximum pressing force and so on.

3 Introduction of capabilities used in new compression molding analysis

In this new compression molding analysis technique, two capabilities which have already been implemented in LS-DYNA are used. Long fibers are modeled by beam elements and polymer matrix by tetrahedral solid elements. Beam elements are constrained in the solid elements by `*CONSTRAINED_BEAM_IN_SOLID` (CBIS) and the solid elements can be highly deformed by 3D adaptive EFG method.

3.1 Coupling function to constrain beam and solid

Beam and solid elements are coupled by `*CONSTRAINED_BEAM_IN_SOLID` (CBIS), which has been implemented since LS-DYNA R8 [5][6]. CBIS is intended to sidestep certain limitations in the `CTYPE=2` of `*CONSTRAINED_LAGRANGE_IN_SOLID` (CLIS) which constrains both accelerations and velocities (constraint based method). Originally CBIS was developed to simulate rebar reinforced concrete. In this new simulation it is applied to long fiber reinforced plastic models. One notable feature of CBIS is that tetrahedral and pentahedral solid elements are supported by a constraint method taking element shape functions into account. On the other hand, `CTYPE=2` of CLIS treats tetrahedra and pentahedra as degenerated hexahedra. CBIS has new coupling option `CDIR=1` which applies only in the beam normal direction, thereby releasing constraint in the beam axial direction. As an additional function of `CDIR=1`, an axial coupling force function has also been implemented. The beam and solid axial debonding processes can be modeled with a user defined function or subroutine giving the axial shear force based on the slip between beam nodes and solid elements. This feature is invoked by setting `AXFOR` flag to a negative integer which refers to the `*DEFINE_FUNCTION` ID or subroutine `rebar_bondslip_get_force()` to a number greater than 1000. Fig.1 shows 3 types of coupling behaviour available in CBIS.

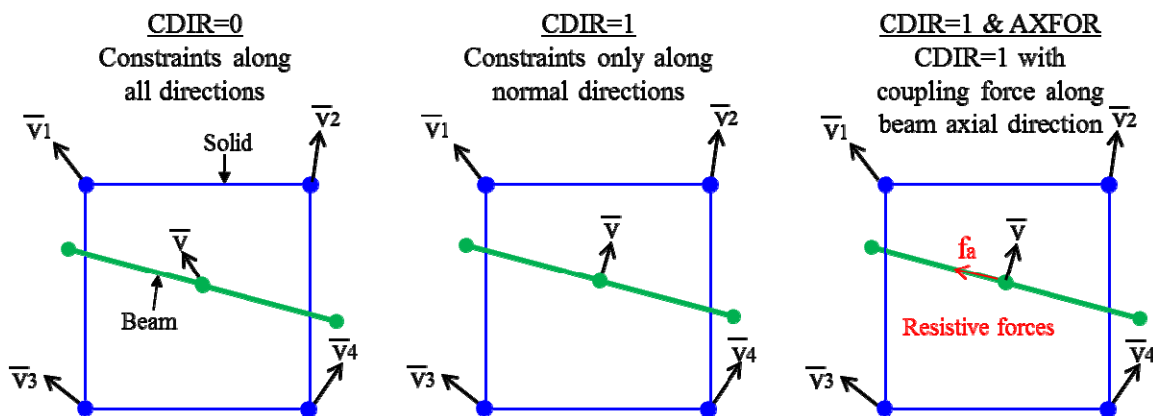

Fig.1: 3 types of coupling option in CBIS

3.2 3D adaptive EFG

A 3D Element-Free-Galerkin (EFG) formulation based on a Mesh-free Galerkin Method was implemented in LS-DYNA 970 during 2001-2002. Following that, a 3D adaptive EFG including r-adaptive remeshing capability was developed in 971 during 2003-2005 to simulate extremely large deformation of metals [5]. Since then many functional enhancements have been added to extend application to metal plasticity forming simulations like 3D forging, extrusion, cold forming, metal cutting, friction stir welding, riveting, etc [7]. 3D adaptive EFG has various features including local mesh-refinement, interactive adaptive method, monotonic mesh resizing and a pressure smoothing scheme, and also it supports thermal conductivity-structural coupling simulation to simulate hot forgings. LS-DYNA has also 3D adaptive FEM (type 13), but 3D adaptive EFG (type 41 and 42) is much more stable and has more functions for mesh refinement. Fig.2 shows an example of 3D forging simulation using 3D adaptive EFG [8].

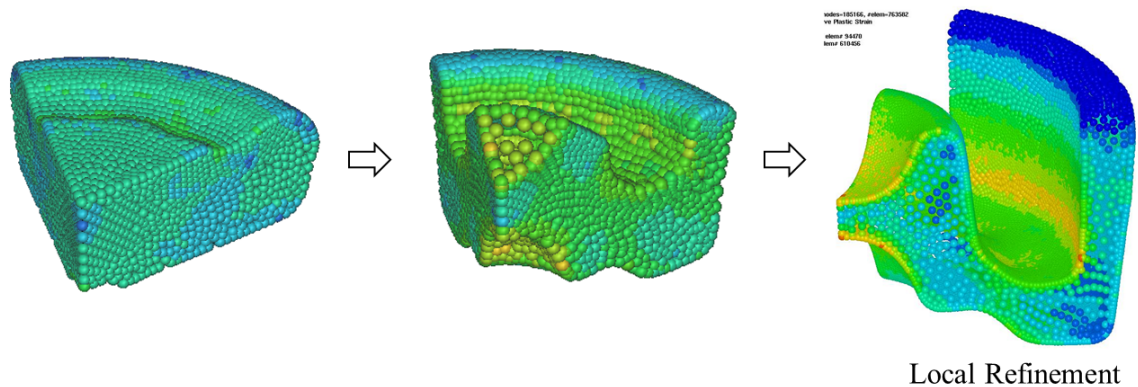

Fig.2: 3D forging simulation example using 3D adaptive EFG

3.3 Simultaneous usage of beam coupling function and 3D adaptive EFG

In May 2016 the idea was conceived in JSOL Corporation (JSOL) to combine the new axial beam coupling function in CBIS (developed for rebar in concrete) with 3D adaptive EFG to simulate compression molding of long fiber reinforced plastics. In this method CBIS continues to constrain the beam elements to the tetrahedral solid elements even during the re-meshing process. Livermore Software Technology Corporation (LSTC) improved the code to enable the simultaneous use of these two functions with the aid of JSOL's testing and feedback. In January 2017 fundamental development was implemented in LS-DYNA development version svn112580 and further enhancements have continued to be added since then.

4 Modelling guideline of beam and solid elements

Time step is generally decided by beam element because fibers have higher stiffness than the matrix so the mesh size of the beam elements has to be considered carefully. When a length of a beam element for carbon fiber is 1mm, its time step becomes less than 0.1 micro second. On the other hand, tetrahedral solid elements for the polymer matrix don't require a small time step but do contribute to the total number of elements. If tetrahedral solid elements are remeshed at a very small size the number of solid elements increases exponentially. In order to perform calculations in a practicable time the mesh size of tetrahedral solid elements must typically be kept larger than 1mm except for local mesh refinement area. CBIS can constrain coupling points (nodes) of multiple beam elements in one solid element as shown in Fig.3. Ideally just one beam coupling point would be constrained in one solid element, however this is unlikely to be practical in a complex shape. Conversely, solid elements containing no beam coupling points should be avoided. In general a higher density of beam elements than solid elements is recommended.

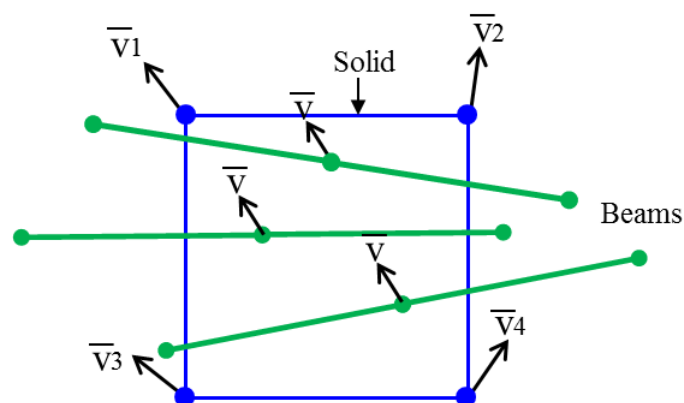

Fig.3: Constraint of multiple beam elements in one solid element

5 How to define macroscopic viscosity

Macroscopic viscosity during compression molding is controlled by both viscosity of the matrix and the resistive forces against fibers sliding axially in the matrix [9]. Fig.4 shows a simple compression simulation model with a test specimen comprising long fibers with 2D random orientation in a matrix of thermoplastic. One fiber is modeled by truss beam elements of `*MAT_ELASTIC`. The matrix is modelled with tetrahedral solid elements of `*MAT_ELASTIC_WITH_VISCOSITY`, which was developed to simulate the forming of glass products at high temperatures.

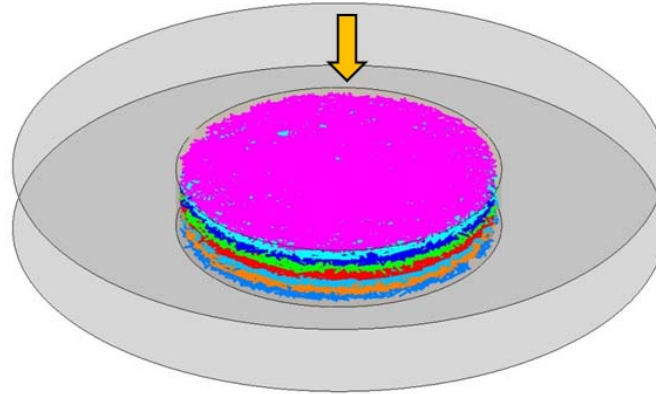

Fig.4: Simple compression model to identify macroscopic viscosity

The model consists of eight layers of matted beam elements which were created by an auto-mesh generator. The beam elements penetrate each other as shown in Fig.5 because the auto-mesh generator could not make a non-penetrating condition. Therefore, a beam-to-beam single contact definition (`*CONTACT_AUTOMATIC_GENERAL`) was not defined in this model. The very large number of fibers in the real FRP material must be represented by a much smaller number of beams in the CAE model; however the beam cross-sectional area is adjusted to ensure the same fiber volume fraction (V_f).

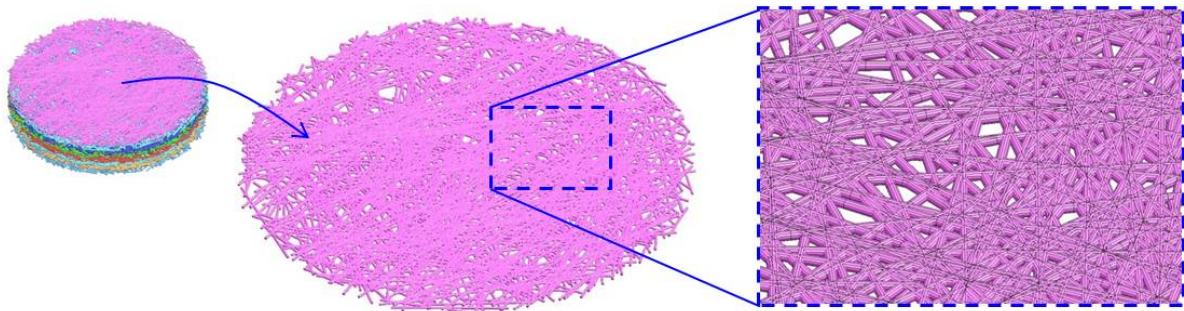

Fig.5: Eight layer model made of beam elements with 2D random orientation

Coupling option of CBIS is `CDIR=1` and `AXFOR=1001` which can define axial coupling force by user subroutine. The axial resistive force is calculated as elastic-perfectly plastic with a maximum resistive force, and the macroscopic viscosity of beam coupling model is defined by combination of this resistive force and viscosity entered as material properties of the matrix. Fig.6 shows the beam axial force contour caused during the compression simulation under large resistive force viscosity. Fig.7 shows contact forces of three simple compression models in which different maximum resistive forces were used. The larger the resistive force used, the larger the contact force that occurs. Thus, macroscopic viscosity can be influenced by the magnitude of resistive force.

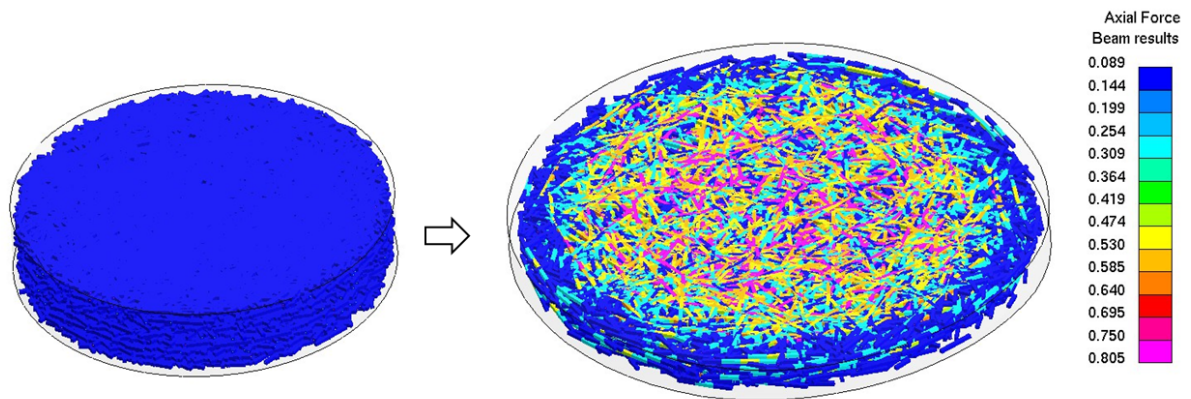

Fig.6: Deformation behaviour and axial forces in beam elements

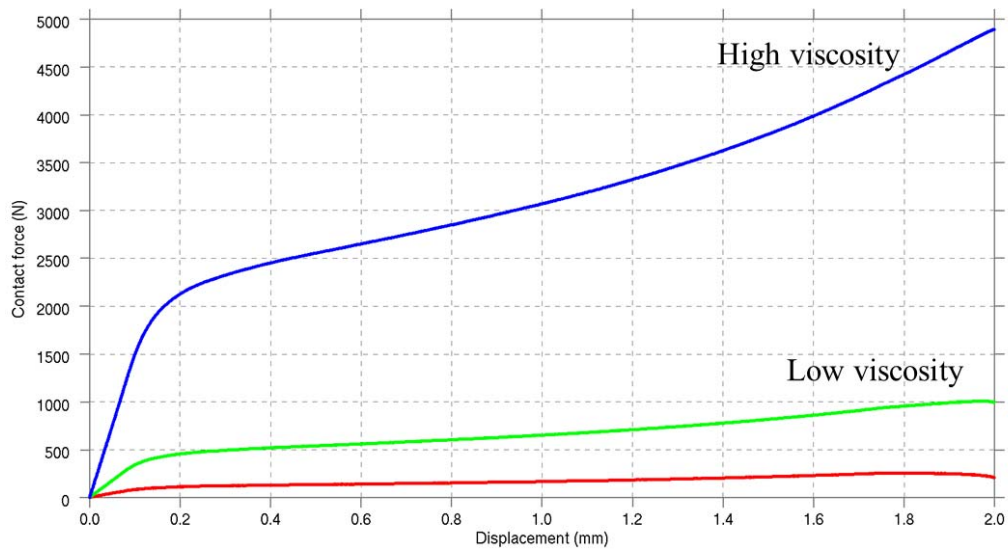

Fig.7: Contact force generated in models with different axial resistive forces

6 Compression molding to form cross-ribbed component

This new technology was tested by comparing LS-DYNA simulation to a real stamped component.

6.1 LS-DYNA model and calculation result

An FRTP stampable sheet model comprising long fibers with 2D random orientation in a matrix of thermoplastics was used as shown in Fig.8.

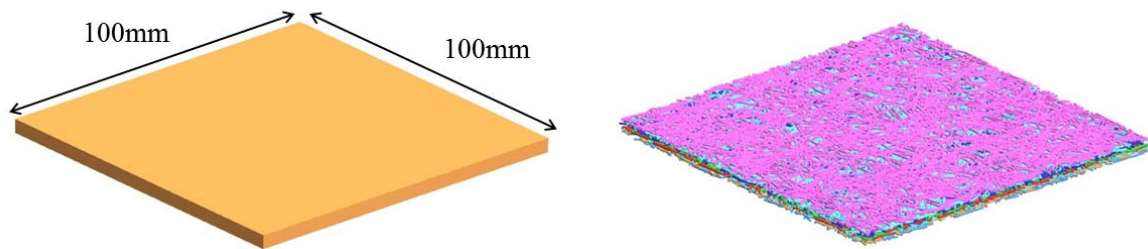

Fig.8: Matrix (EFG solid elements) shown left and 2D-random orientation fiber model (beam elements) shown right

Fig.9 shows the compression molding model used in this study. The punch deforms the charge into a complex shaped part with cross-rib of 15mm height. The size of FRTP stampable sheet is small but enough to evaluate the performance the coupled method between beam and 3D Adaptive EFG.

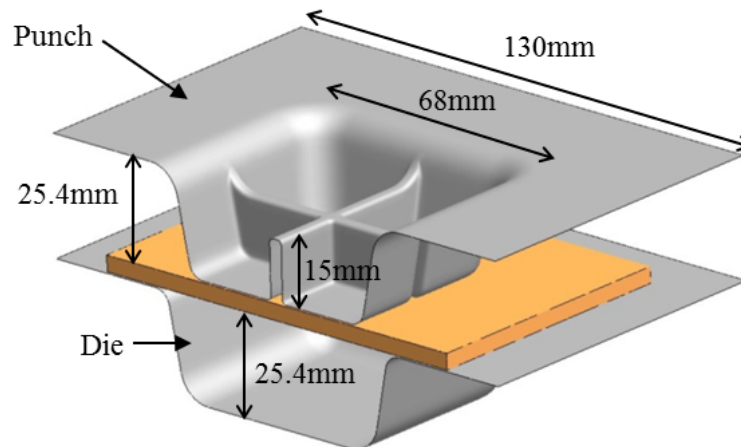

Fig.9: Compression molding model to form cross-rib shaped component

In the real compression molding process the fiber reinforced thermoplastic is heated beyond the melting temperature of the matrix then pressed into complex shapes while the fibers slide in the semi-liquid matrix.

Fig.10 shows the deformation behaviour of the solid element matrix (on the left) and beam element fibers (on the right). In the final shape, matrix and fibers have completely filled the cross-rib voids. The LS-DYNA calculation was very stable and ended with normal termination.

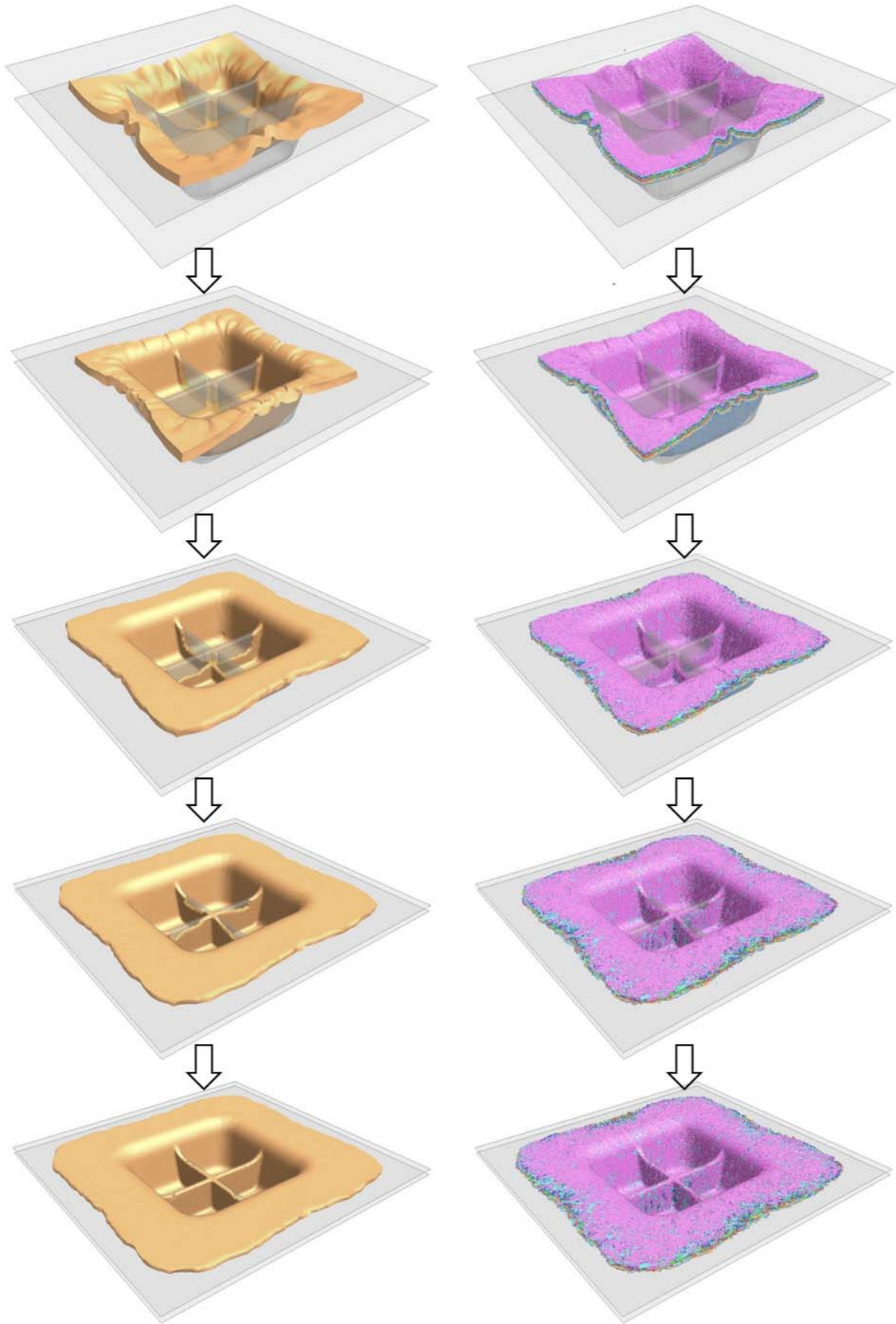

Fig.10: Deformation behaviour of solids as matrix (left) and beams as fibers (right)

Fig.11 shows the forming behaviour of ribs generated by r-adaptive remeshing and beam elements. The local mesh refinement function of the r-adaptive capability was used for areas around the ribs. Weld lines are predicted at the top edge of the ribs and the fibers are oriented along the weld lines. The density of beam elements can be viewed to see fiber volume fraction distribution which can be used to determine matrix rich regions.

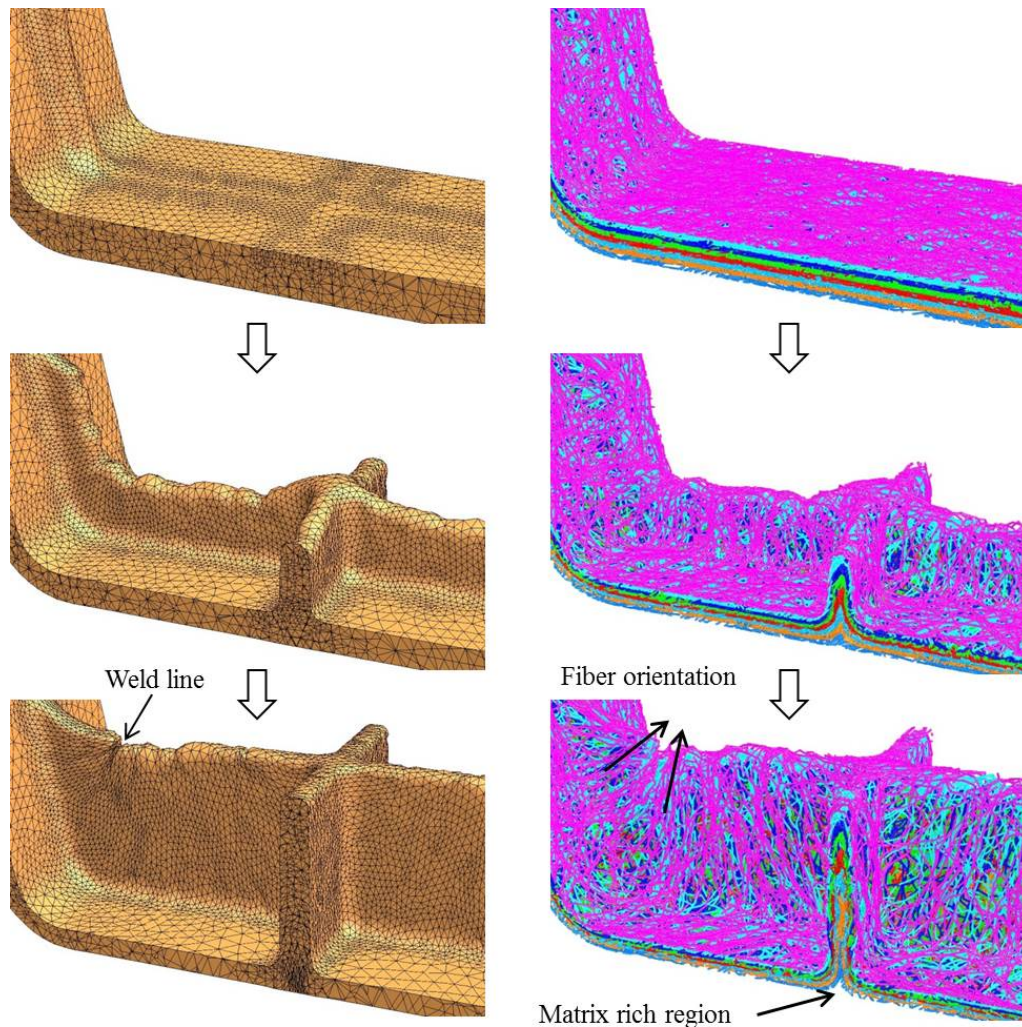

Fig.11: EFG r-adaptive mesh refinement and beam orientation behaviour

6.2 Comparison of test and LS-DYNA

A compression molding test was performed to evaluate this new simulation technology of LS-DYNA. In this test, long glass fiber reinforced thermoplastic material (GFRTTP) was used (Tepex[®] flowcore from Bond-Laminates GmbH). As shown in Fig.12 the punch shape used in the LS-DYNA simulation is exactly the same as that used in the test.

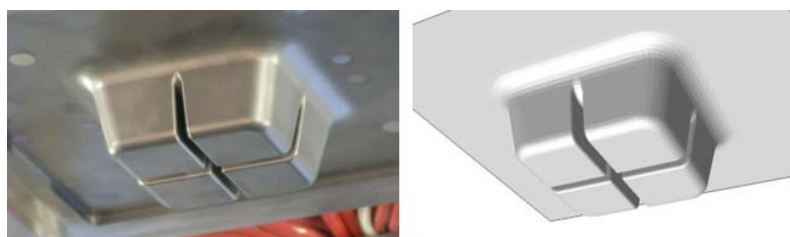

Fig.12: Punch shape used in experiment and LS-DYNA

Fig.13 (left) shows deformations mid-way through the compression molding test of GFRTP sheet. Large wrinkles occur around the edge of the sheet. The LS-DYNA result seen in Fig.12 (right) shows good agreement to test.

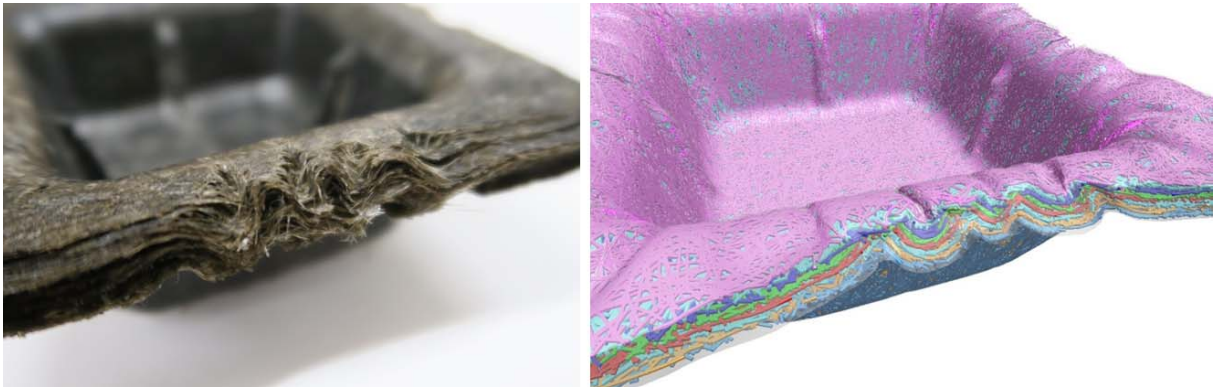

Fig.13: Charge wrinkling mid-way through the punching process

Later in the stamping process the GFRTP fills into the cross-ribs. Fig.14 shows deformations of the test and LS-DYNA where the punch stroke has reached near bottom. The charge pattern predicted by LS-DYNA is very similar to that seen in test and the realistic formulation of weld lines can be seen.

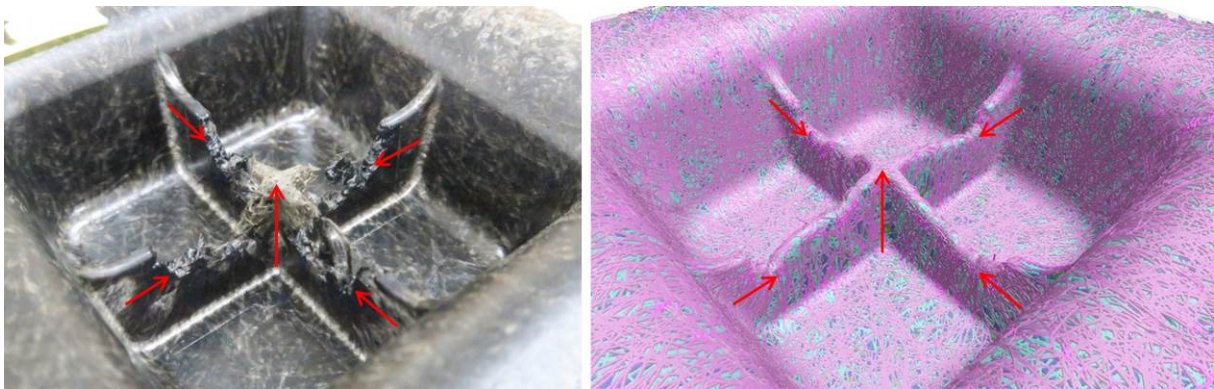

Fig.14: Formation of ribs and weld lines near the final punch stroke

Fig.15 shows final forming shapes from test and LS-DYNA. The total footprint of expanded material is predicted to be the same as seen in test.

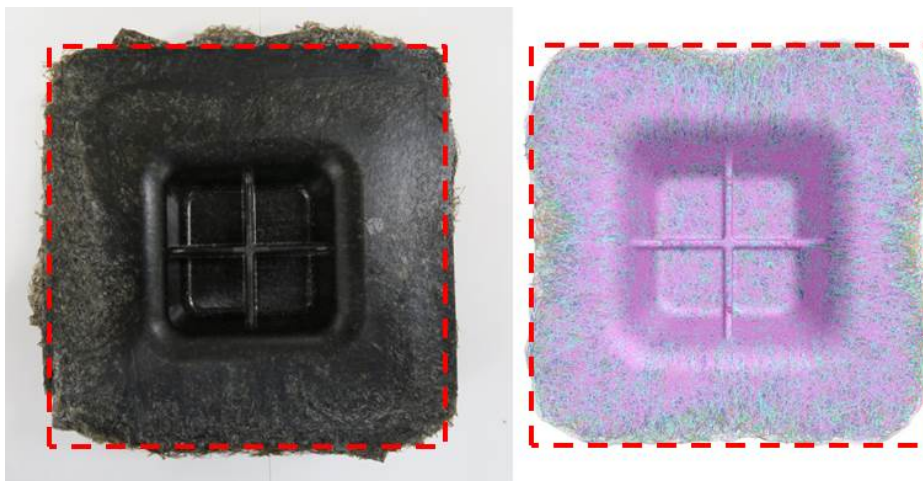

Fig.15: Total footprint of expanded material

7 Thermal conductivity / structural analysis of compression molding

To calculate even more realistic compression molding, simulation coupling thermal conductivity with the above analysis techniques has under research at JSOL. In the real stamping process the macroscopic viscosity changes according to matrix temperature. In the latest development version of LS-DYNA a user subroutine describing resistive force of CBIS is passed the temperature value at a beam coupling point as one argument. This temperature value is calculated by interpolation of temperatures at nodes of a solid to which the beam is coupled.

8 Summary

This new simulation technology has great potential to simulate compression molding of long fiber reinforced plastics with high accuracy and provides much valuable data in analysis results:

- Filling behavior and timing
- Fiber orientation and deformation
- Axial force of fiber
- Stress occurring in matrix
- Identification of weld line locations and matrix rich region
- Distribution of fiber volume fraction (Vf)
- Punch reaction force
- Other measureable values

9 Ongoing research at JSOL

- Development of methodology to identify parameters of macroscopic viscosity
- Further comparison of compression molding tests presented in this paper and LS-DYNA results
 - Fiber orientation observed by CT scan or Scanning Electron Microscope (SEM)
 - Punch reaction force
- New compression molding tests of long carbon fiber reinforced thermoplastics
 - Generally the formability of carbon FRP in compression molding is worse than glass FRP. This new simulation technology will be verified against the compression molding of various FRP materials.
- Component strength analysis using beam elements deformed by compression molding simulation
 - In this technique beam elements are carried over from the results of compression molding simulations so that it is not necessary to use any mapping method to create homogeneous material properties from fiber orientation. In order to validate this technique, it will be compared with not only a strength experiment but also a conventional simulation method using a homogeneous material with fiber orientation mapped from the beam elements.

10 Future development for LS-DYNA

The adaptive mesh refinement processes of adaptive EFG takes a relatively large calculation time. In order to reduce this cost, adaptive SPG (Smoothed Particle Galerkin method) is proposed instead of adaptive EFG. Adaptive SPG is now being developed in LSTC and may show potential for shorter run times than adaptive EFG. Once complete, further research at JSOL will include component strength analysis using a model of coupling beam and adaptive SPG techniques. SPG can simulate failure and crack phenomena of materials with high accuracy. Furthermore, new coupling option of CBIS will be implemented to simulate strength of long fiber reinforced plastic models.

LSTC and JSOL will continue to develop these and other new simulation technologies for composite materials.

11 Acknowledgments

We would like to show grateful appreciation to engineers of Asano Co.,Ltd. who performed high quality GFRTM compression molding tests. We would also like to thank Kentaro Sakoda, Hitoshi Oura and Sean Wang of JSOL Corporation for their efforts performing this study.

12 Literature

- [1] Romanenko V., Duhovic M., Hausmann J., Eschl J.; "DEVELOPMENT OF ADVANCED 3D PROCESS SIMULATION FOR CARBON FIBER SHEET MOLDING COMPOUNDS IN AUTOMOTIVE SERIES APPLICATIONS", 17th European Conference on Composite Materials (ECCM17), Munich, Germany, 26-30th June 2016
- [2] Masatoshi Kobayashi, Koji Dan, Tsuyoshi Baba, Daisuke Urakami: "COMPRESSION MOLDING 3D-CAE OF DISCONTINUOUS LONG FIBER REINFORCED POLYAMIDE 6: INFLUENCE ON CAVITY FILLING AND DIRECT FIBER SIMULATIONS OF VISCOSITY FITTING METHODS", 20th International Conference on Composite Materials, Copenhagen, 19-24th July 2015
- [3] Hiroaki MATSUTANI, Ichiro TAKETA, Masahiro HASHIMOTO, Noriyuki HIRANO, Tomonaga OKABE; "Flow Simulation of Thermoplastic Stampable Sheet Using Parcile Method", Journal of the Japan Society for Composite Materials, 40, 5(2014), P227-237
- [4] Dminic Schommer, Miro Duhovic, Florian Gortner, Martin Maier: "Advanced Simulation of Polymer Composite SMC Compression Molding using Fluid-Structure Interaction in LS-DYNA", 13th International LS-DYNA Users Conference, Dearborn, MI, USA, 2014
- [5] LSTC; "LS-DYNA KEYWORD USER'S MANUAL" 03/03/17 (r:8240) LS-DYNA Dev
- [6] Hao Chen; "An Introduction to *CONSTRAINED_BEAM_IN_SOLID", FEA Information, Page 79-83, Volume 5, Issue 10, October 2016
- [7] Hongsheng Lu, C. T. Wu, Jingxiao Xu: "Forging and Extrusion Analysis with LS-DYNA using 3D Adaptive EFG Method", 10th International LS-DYNA Users Conference, Dearborn, MI, USA, 2008
- [8] Wei Hu, C. T. Wu, Yong Guo, Bo Ren, Youcai Wu: "LS-DYNA Advanced FEM and Meshfree Methods for Solid and Structural Analyses - Manufacturing Applications", LS-DYNA Training Class, Jun. 15th-16th, 2016, Detroit
- [9] Yuuji Okabayashi, Shigeki Yashiro, Yoshihisa Sakaida: "Estimating macroscopic viscosity of discontinuous fiber reinforced thermoplastic stampable base material using particle method", 7th Japan Conference on Composites Materials, Japan, 2016